

## CAUTION



Risk of explosion if the battery is replaced by an incorrect type  
Wait one-half hour after switching off before handling parts.

- Replacement of a battery with an incorrect type that can defeat a safeguard;
- Disposal of a battery into fire or a hot oven, or mechanically crushing or cutting of a battery, that can result in an explosion;
- Leaving a battery in an extremely high temperature surrounding environment that can result in an explosion or the leakage of flammable liquid or gas;
- A battery subjected to extremely low air pressure that may result in an explosion or the leakage of flammable liquid or gas.

This device complies with Industry Canada licence-exempt RSS standard(s). Operation is subject to the following two conditions: (1) this device may not cause interference, and (2) this device must accept any interference, including interference that may cause undesired operation of the device.

Le présent appareil est conforme aux CNR d'Industrie Canada applicables aux appareils radio exempts de licence. L'exploitation est autorisée aux deux conditions suivantes : (1) l'appareil ne doit pas produire de brouillage, et (2) l'utilisateur de l'appareil doit accepter tout brouillage radioélectrique subi, même si le brouillage est susceptible d'en compromettre le fonctionnement.

### FCC Radiation Exposure Statement:

This equipment complies with FCC RF radiation exposure and Industry Canada RSS-102 RF exposure limits set forth for an uncontrolled environment. This device and its antenna must not be co-located or operating in conjunction with any other antenna or transmitter. To comply with FCC RF exposure and Industry Canada RSS-102 RF exposure compliance requirements, this grant is applicable to only Mobile Configurations. The antennas used for this transmitter must be installed to provide a separation distance of at least 20 cm from all persons and must not be co-located or operating in conjunction with any other antenna or transmitter.

Cet équipement est conforme aux limites d'exposition aux rayonnements énoncées pour un environnement non contrôlé et respecte les règles d'exposition aux fréquences radioélectriques (RF) CNR-102 de l'IC. Cet équipement doit être installé et utilisé en gardant une distance de 20 cm ou plus entre le radiateur et le corps humain (à l'exception des extrémités : mains, poignets, pieds et chevilles).

# NMP599-W-2

## Quick Start Guide

This printed quick start guide provides a quick walk-through of the setup process. For complete documentation, please visit <http://www.viewsonic.com/us/support>.

## Box Content

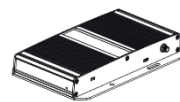

NMP599-W-2  
Device



Power adapter



Wi-Fi antenna

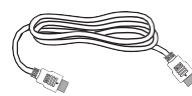

HDMI cable



Velcro (2sets)



Power bracket and  
micro-SD card bracket  
and screw\*2



Device quick  
guide



Software quick  
guide

## Mounting and Installation (USB mouse required)

1. Attach the wireless antenna by screwing the antenna clockwise onto the post.
2. Mount the media player to the back of the monitor using the Velcro strips.
  - i. Separate the Velcro strip into singles.
  - ii. Attach one strip onto the bottom flat surface of the media player.

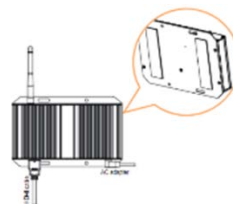

3. Attach the other strip to the surface on the back of the display.
4. Secure the media player to the display.
5. Connect the HDMI cable and AC adapter.

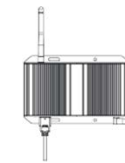

## Port Connections

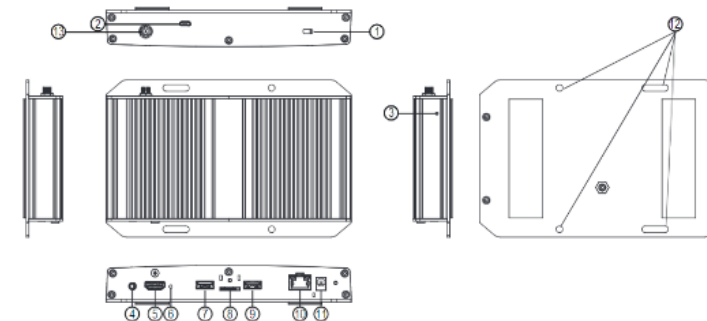

1. Kensington lock
2. ADB
3. Reset
4. Audio out

5. HDMI out
6. Power LED
7. USB port
8. Micro SD

9. USB port
10. Ethernet/PoE
11. DC in

12. Mounting hole (screw spec: M4)
13. Wireless antenna port

## System Setup

1. Device Startup  
Plug in the AC adapter to the media player and it will power on automatically. Once the user has exited the boot up screen, users can go through system configurations in both landscape and portrait orientations.

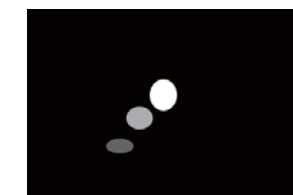

## 2. Autoplay Content

When boot up is complete, if the system detects preloaded content, the loading circle will appear. Once the loading circle completes, content will be played. To stop autoplay and enter “**Basic settings**” users need to select the pause button in the center of the loading circle.

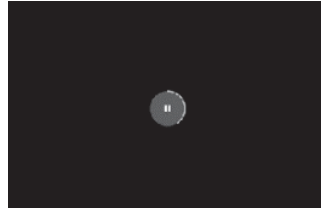

## 3. Basic settings

When boot up is complete and there is no preloaded contents, the user will see the “Basic settings” which allows the user to make configurations or autoplay pre-loaded content.



## 4. Make configurations

To change media player system language, use a USB mouse to select “**(Current Language)...**” For system configurations, select “**Advanced.**”



Important recommended configurations:

1. Set correct time, date and time zone for properly scheduled playback.
2. Set password to prevent unauthorized access during setup menu.
3. Set network for establishing network connection.

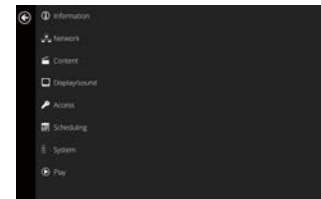

## 5. Set content

Users can set content by clicking “**Set Content**” to enter the URL or use the desired content management system to upload the contents onto the media player.



## Content Management

Please consult the software documentation for information specific to your content management solution.

## Troubleshooting

How do I interrupt playback and enter setup menu?

Use USB mouse to click and hold one corner of the screen for 10 seconds to exit playback and enter setup menu.

How do I provide a DEBUG log for a behaving media player to the support team?

Please follow the instructions below to collect the player’s DEBUG log:

- 1 Prepare a blank USB stick in FAT-32 format.
- 2 Create a folder name “DEBUG” (case insensitive) in the root of USB stick.
- 3 Make sure the player is operating (see welcome screen or playing content)
- 4 Insert the USB stick into player and wait for yellow dot on upper right corner to stop blinking.
- 5 Within the “DEBUG” folder, is a folder with a string of number as its name. If the string of numbers is all zero’s, the debug log has not been collected properly. Repeat step 1~4 again and make sure to wait until stop blinking.
- 6 Zip the “DEBUG” folder and send to ViewSonic Support Team.

## How to reset the media player to factory default

Factory resetting the media player will result in the removal of all saved contents, passwords and configurations in settings. Please refer to the steps below to complete the media player factory resetting process:

- 1 Use a pen to press and hold the reset button – do not release until step 4.
- 2 Insert the power cord.
- 3 Wait 30 seconds for the system reboot indicates that your data is erased.
- 4 Release the reset button and the media player will initialize to factory default state.

## CARE AND WARNING

**WARNING:** Changes or modifications to this unit not expressly approved by the party responsible for compliance could void the user’s authority to operate the equipment.

**NOTE:** This equipment has been tested and found to comply with the limits for a Class A digital device, pursuant to part 15 of the FCC Rules. These limits are designed to provide reasonable protection against harmful interference when the equipment is operated in a commercial environment. This equipment generates, uses, and can radiate radio frequency energy and, if not installed and used in accordance with the instruction manual, may cause harmful interference to radio communications. Operation of this equipment in a residential area is likely to cause harmful interference in which case the user will be required to correct the interference at his own expense. This device complies with Part 15 of the FCC Rules. Operation is subject to the following two conditions: (1) This device may not cause harmful interference, and (2) this device must accept any interference received, including interference that may cause undesired operation.

## Information

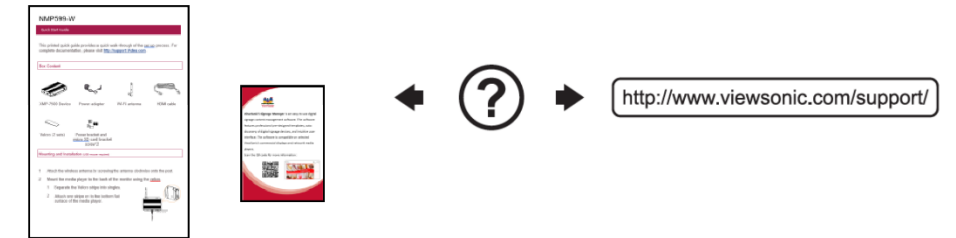

## Support

**中国**  
<http://www.viewsonic.com.cn>  
电话：4008 988 588

**香港**  
<http://www.hk.viewsonic.com>  
電話：852 3102 2900

**澳門**  
<http://www.hk.viewsonic.com>  
電話：853 2840 3687

**台灣**  
<http://www.viewsonic.com.tw>  
電話：0800 061 198

**한국**  
<http://ap.viewsonic.com/kr/>  
Phone: 080 333 2131

**Singapore/Malaysia/Thailand**  
<http://www.viewsonic.com.sg>  
Phone: 65 6461 6044

**India**  
<http://www.in.viewsonic.com>  
Phone: 1800 419 0959

**United States**  
<http://www.viewsonic.com>  
Phone: 1-800-688-6688 (Toll-Free)  
1-424-233-2530 (Toll)

**Canada**  
<http://www.viewsonic.com>  
Phone: 1-866-463-4775 (Toll-Free)  
1-424-233-2533 (Toll)

**Europe**  
<http://www.viewsoniceurope.com>  
[www.viewsoniceurope.com/uk/support/call-desk/](http://www.viewsoniceurope.com/uk/support/call-desk/)

**Australia/New Zealand**  
<http://www.viewsonic.com.au>  
Phone: 1800 880 818 (AUS)  
0800 008 822 (NZ)

**South Africa**  
<http://ap.viewsonic.com/za/>

**Latin America (Chile)**  
<http://www.viewsonic.com/la/>  
<http://www.viewsonic.com/la/soporte/servicio-tecnico>

**Latin America (Mexico)**  
<http://www.viewsonic.com/la/>  
<http://www.viewsonic.com/la/soporte/servicio-tecnico>

**Latin America (Peru)**  
<http://www.viewsonic.com/la/>  
<http://www.viewsonic.com/la/soporte/servicio-tecnico>

**Latin America (Argentina)**  
<http://www.viewsonic.com/la/>  
<http://www.viewsonic.com/la/soporte/servicio-tecnico>

**Puerto Rico & Virgin Islands**  
<http://www.viewsonic.com>  
Phone: 1-800-688-6688 (English)  
<http://www.viewsonic.com/la/soporte/servicio-tecnico>