

LDM163-182

All-in-One Direct View LED Display

Installation Guide

快速入門指南

Guide de démarrage rapide

Schnellstartanleitung

Guía rápida de inicio

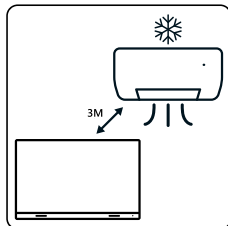
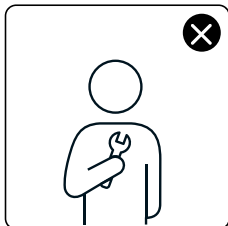
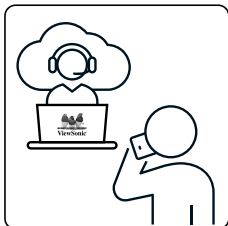
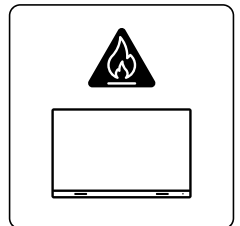
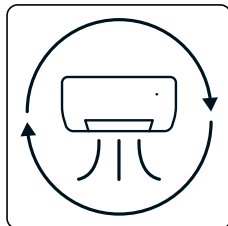
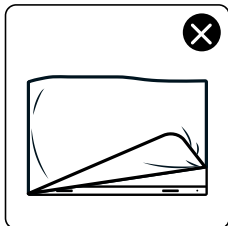
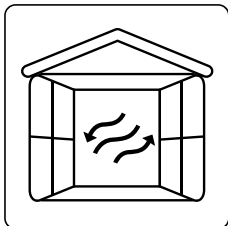
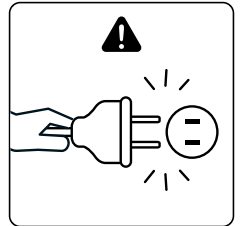
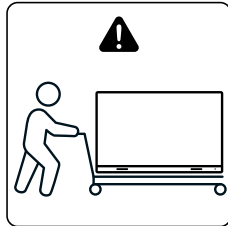
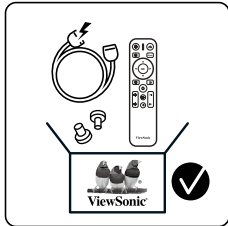
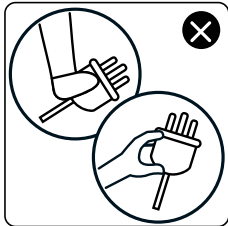
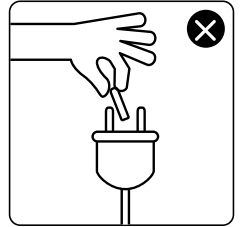
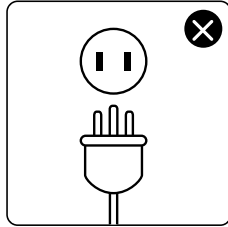
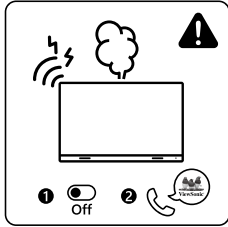
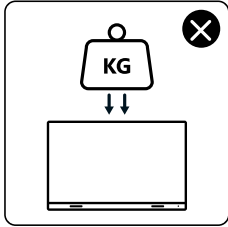
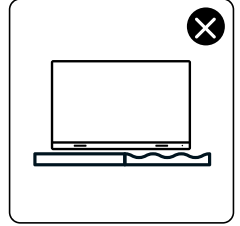
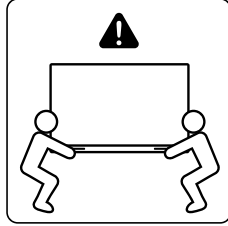
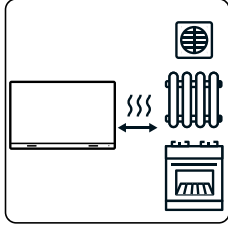
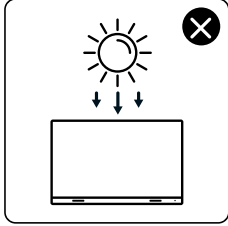
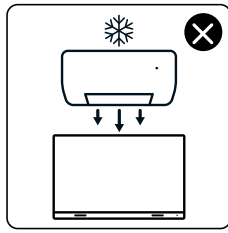
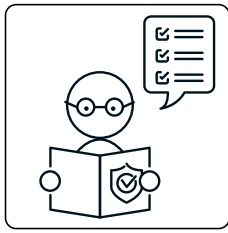
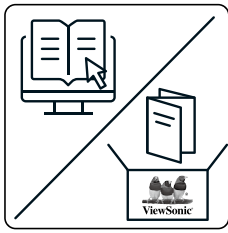

FCC Compliance Statement

This device complies with part 15 of FCC Rules. Operation is subject to the following two conditions: (1) this device may not cause harmful interference, and (2) this device must accept any interference received, including interference that may cause undesired operation.

Industry Canada ICES-003 Statement: CAN ICES-003(B) / NMB-003(B)

CE Conformity for European Countries

The device complies with the EMC Directive 2014/30/EU, Low Voltage Directive 2014/35/EU and Radio Equipment Directive 2014/53/EU.

Declaration of RoHS2 Compliance

This product has been designed and manufactured in compliance with Directive 2011/65/EU of the European Parliament and the Council on restriction of the use of certain hazardous substances in electrical and electronic equipment (RoHS2 Directive) and is deemed to comply with the maximum concentration values issued by the European Technical Adaptation Committee (TAC).



LDM163-182



Support Center



www.viewsonic.com



ViewSonic Europe Limited

Haaksbergweg 75
1101 BR Amsterdam
Netherlands



+31 (0) 650608655



EPREL@viewsoniceurope.com











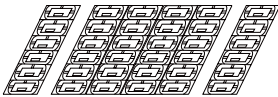

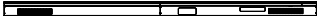
<https://www.viewsonic.com/eu/>

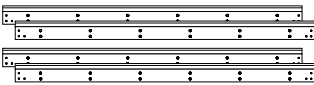

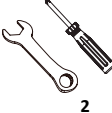
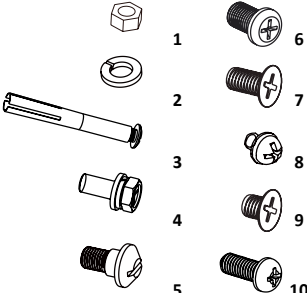

Package Contents

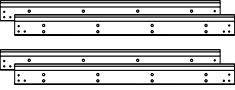
- ❗ It is recommended to use pliers to open the shipping crate.
- ❗ Please wear protective gear, such as gloves and protective shoes, at all times.

Before the installation, please take a moment to check if all components are included in the crate. If anything is missing or damaged, contact your dealer immediately.

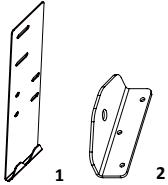
	Item	Quantity	Note
Installation Guide		1	
Cabinet Sections		6 sections total	One Left (F), four Middle (E, D, C, B), and one Right (A)
LED Modules		148 modules	The quantity of spare LED modules varies by country.
Screen Bezels		12	4 x Right (R) 1 x Top Right (R1) 1 x Bottom Right (R6) 4 x Left (L) 1 x Top Left (L1) 1 x Bottom Left (L6)
System Control Box		2 sides	
System Control Box Covers		2 sides	
Connector Plate		1	
System Control Box Maintenance Tool (LD-MK-004)		1	
Wall Mount Brackets		4	1799 mm

Item	Quantity	Note
Wall Mount Connector Plates		2
IR Extension Cable (3 m)		1
Hand Tools		2 x Cross-head screwdrivers (1) 2 x Ratcheting wrenches (2)
Nuts and Bolts		2 x M8 nuts (1) 20 x M8 lock washers (2) 20 x M8 x 80 mm expansion (3) 74 x M8 x 20 mm (4) 2 x M8 x 16 mm (5) 12 x PM6 x 10 mm (6) 16 x M3 x 10 mm (7) 6 x M3 x 5 mm (8) 5 x M2.5 x 4 mm (9) 10 x PM3 x 10 mm (10)
Anti-Static Gloves		2 pairs
Remote Control		1 With two AAA batteries
Wall Mount Brackets (Hidden Installation)		4 1335 mm
Screen Bezels (Hidden Installation)		4

Item	Quantity	Note
System Control Box Mount Brackets (Hidden Installation) 	4	2 x Upper (1) 2 x Lower (2)
Cable Zip Ties (Hidden Installation)	 36	
Cabinet Cable Extensions (Hidden Installation)	 6	
Ethernet Cable (3.5 m)	 6	

NOTE:

- This product is packed in a wooden crate.
- Due to the size and weight, it is recommended that two or more people handle it.
- You can identify the contents inside the case by the product labels on it.
- The base stand (trolley) is an optional accessory and sold separately.

Product Overview

Front Panel

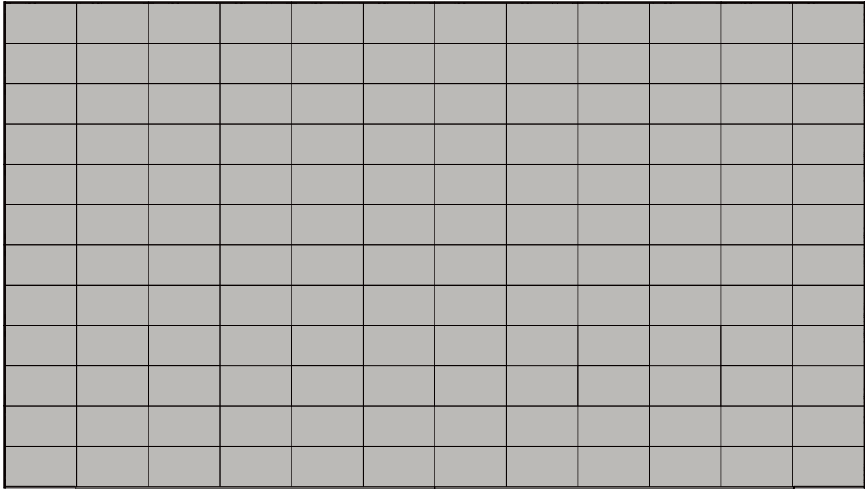

Speaker

HDMI & Audio Out

Speaker

I/O & Control Panel

Rear Panel

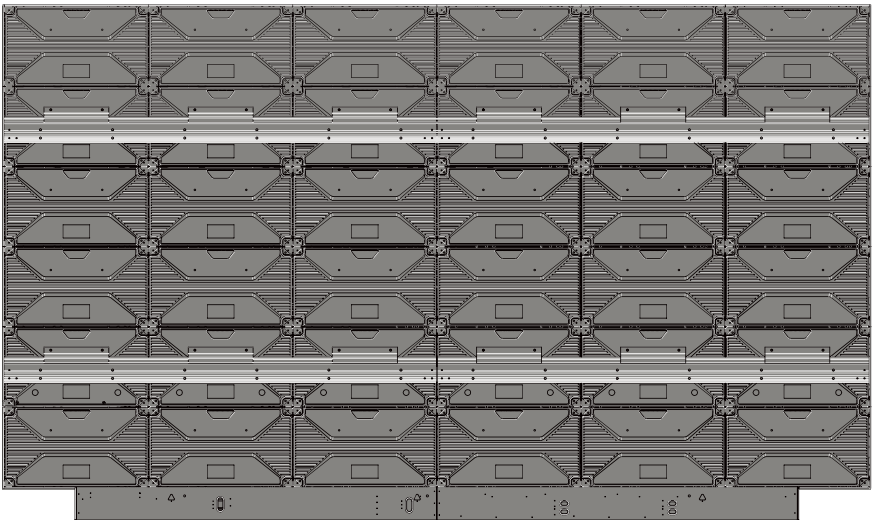

Introduction

The step-by-step instructions in this guide are a general reference for installing the LED Display. If any details in this document are unclear, please contact your reseller for more information.

It is recommended to ask your reseller or licensed professional to install the LED Display.

About the LED Display

The LED Display can be installed on the wall or on a trolley.

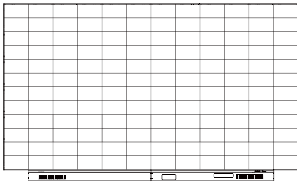

Wall Installation

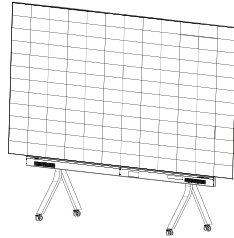

Trolley¹

You can mount the System Control Box in three different ways:

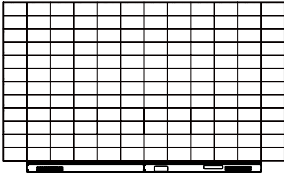

Under the Cabinets
(Standard Installation)

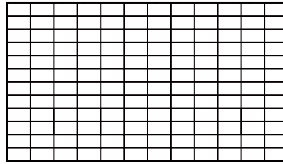

Behind the Cabinets
(Hidden Installation)

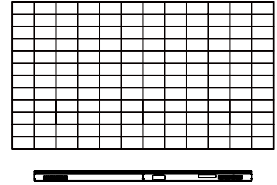

Apart from the Cabinets
(Separate Installation)

The following sections describe each installation type in detail.

¹ - Hidden and Separate Installation are not applicable to the trolley.

Before Installing

- ❗ Ensure there is no direct airflow from air conditioning or heating vents blowing on the display.
- ❗ Avoid installing the LED Display in places with high humidity.
- ❗ Due to high power usage, always use power cords specifically designed for this product.
- ❗ Wood may split if holes are not pre-drilled before installing the Wall Mount Brackets.
- ❗ Ensure that the wall can safely support 227 kg and the power outlet supplies enough voltage (max: 2624W; normal: 918W).
- ❗ Ensure the deviation of the wall surface is < 5 mm.
- ❗ Wear protective gear, such as gloves and protective shoes, when handling the LED Display.

Wall Mounting (Standard Installation)

Four Wall Mount Brackets are used for mounting the screen to the wall.

Installing the Upper and Lower Wall Mount Brackets

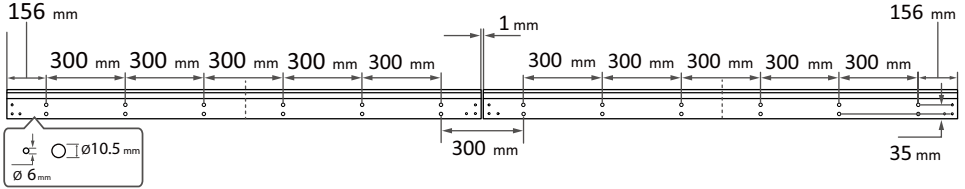

1. Ensure the wall area is an appropriate installation site.
NOTE: Refer to page 12 for more information.
2. Using the illustration as shown above as a guide, mark at least 12 mounting holes and pre-drill them.
3. Install the first Upper Wall Mount Bracket with the provided screws (M8 x 80 mm Expansion for masonry; wood screws for load bearing wood).
4. Repeat **Step 2**, ensuring the second Upper Wall Mount Bracket is level with the first Upper bracket.
NOTE: It is recommended to use a laser or torpedo level.
5. After mounting the first and second Upper Wall Mount Brackets to the wall, secure them with the Wall Mount Connector Plate using the six provided screws (PM6 x 10 mm).

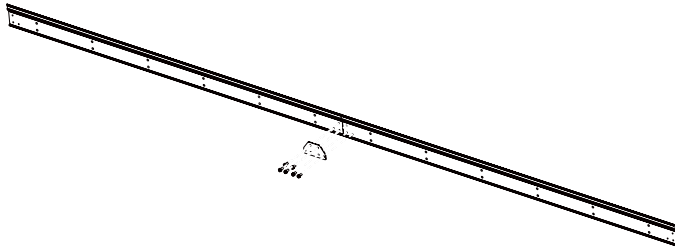

6. Install the Lower Wall Mount Brackets in the same manner as the Upper Wall Mount Brackets. The distance between the Upper and Lower Wall Mount Brackets is 1012.5 mm.

7. After installing both Upper and Lower Wall Mount Brackets, the installation wall should look like:

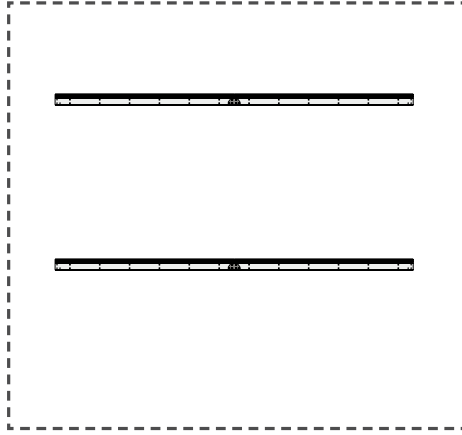

After the Wall Mount Brackets are installed, please go to page 23 for the Cabinets (Standard Installation).

Spacing Instructions for Wall Installation (Standard Installation)

ENGLISH

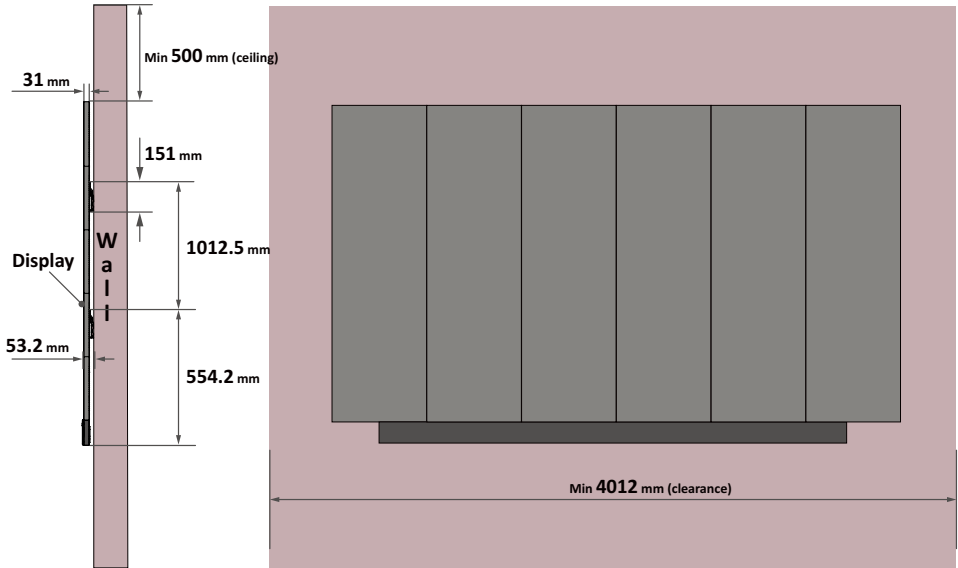

NOTE:

- You can also install the Upper Wall Mount Brackets, hang the screen, and then install the Lower Wall Mount Brackets for a more precise fit.
- Adjustment in floor clearance and ceiling height should be made according to the actual installation site.

Trolley Mounting

The floor stand (trolley) is an optional accessory. Follow below instructions to build and install your LED Display onto the trolley.

NOTE: The trolley is compatible only with ViewSonic Direct View LDM136-151 and LDM163-182. Using the trolley with other models may cause instability and injury.

Before Building

- ❗ DO NOT move the trolley over cords or uneven, dirty, soft, or high incline surfaces.
- ❗ To avoid injury, KEEP AWAY from moving parts.
- ❗ DO NOT move the trolley by pushing on the LED Display.
- ❗ DO NOT push the trolley from the front of the LED Display or attempt to lift it.

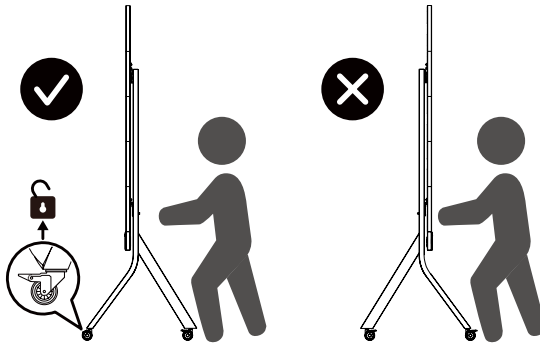

Component List



Left and Right Supports

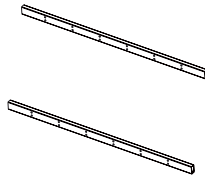

Top and Bottom Cross Beams



Upper Wall Mount Brackets¹

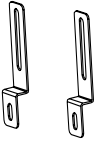

Cabinet Brackets

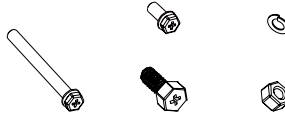

Nuts and Bolts

Trolley

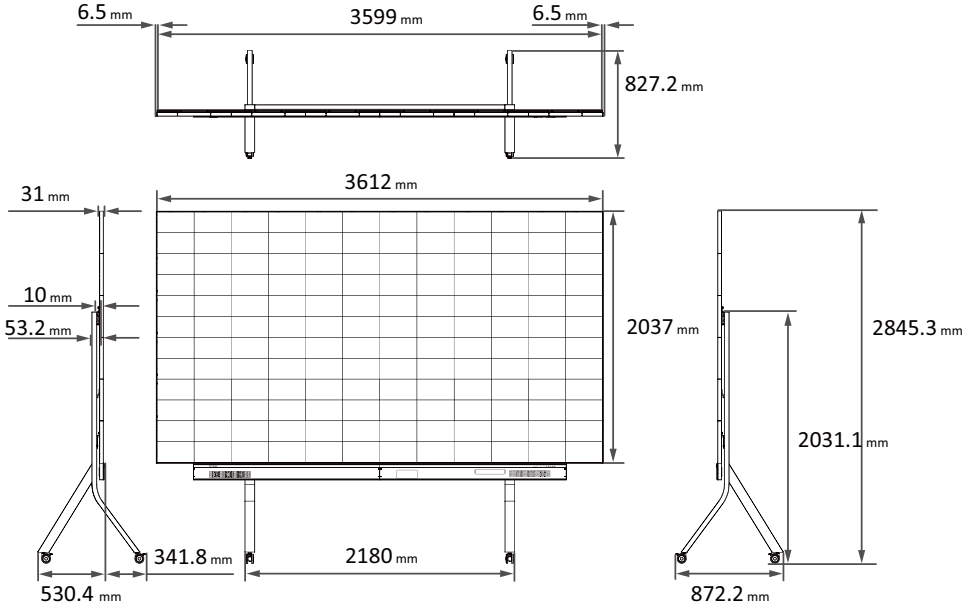

1 - You don't need the Lower Wall Mount Brackets for this mounting system.

Building the Trolley

1. Install the Top and Bottom Cross Beams to the Left and Right Supports. Secure them together with the provided screws (M8 x 20 mm).

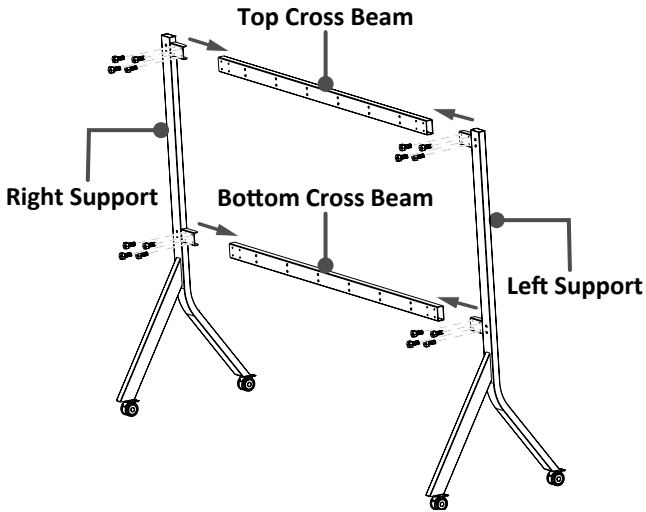

Building the Trolley (Rear View)

2. Connect the first and second Upper Wall Mount Brackets using the Wall Mount Connector Plate with the six provided screws (PM6 x 10 mm).

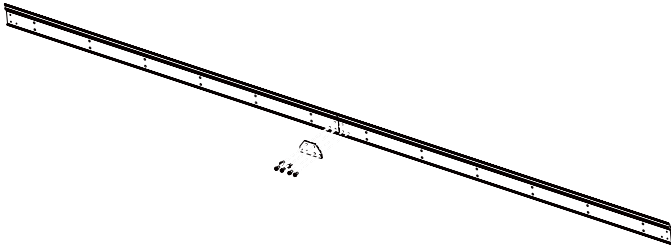

3. Install the Upper Wall Mount Brackets to the Top Cross Beam with the provided screws (M8 x 80 mm), lock washers, and nuts.

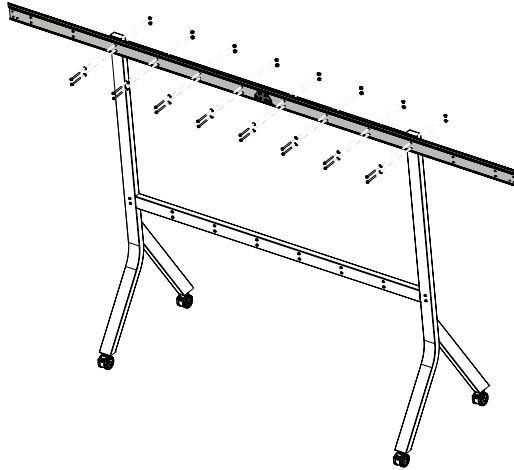

4. Install the Cabinet Brackets to the lower side of the Left and Right Supports with the provided screws and nuts. The Cabinet Brackets are used later for further securing the lower part of the Cabinets to the trolley.

NOTE: There are two Cabinet Brackets to install.

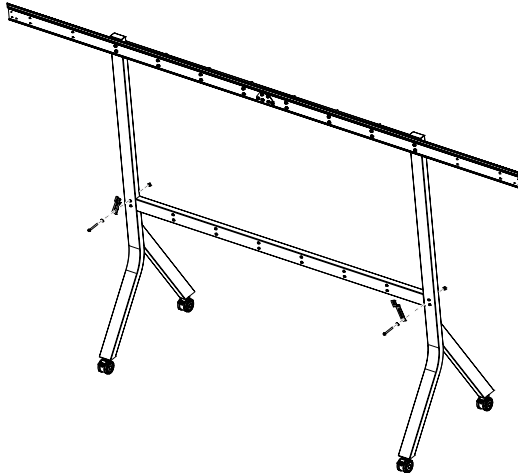

5. Ensure all parts are accurately and securely held together, as shown in the diagrams below.

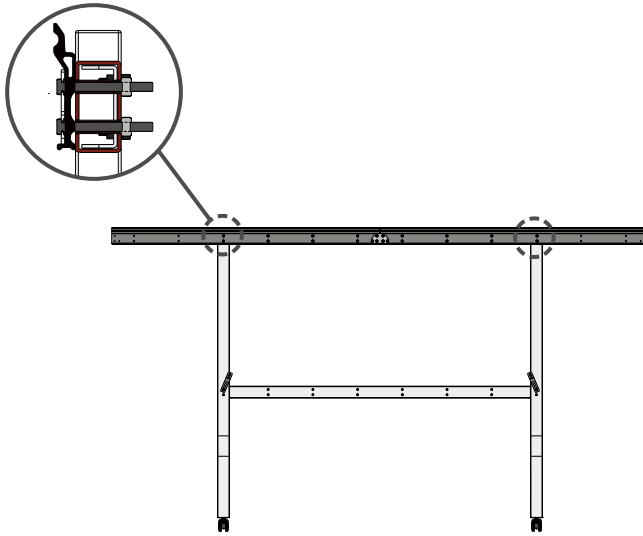

After the trolley is built, please go to page 27 for the Cabinets.

Wall Mounting (Hidden Installation)

When the System Control Box is installed behind the Cabinets, this installation type requires a different set of Wall Mount Brackets. You also need the System Control Box Mount Brackets to attach the System Control Box to the rear of the Cabinets.

Wall Mounting

Four Wall Mount Brackets are used for mounting the screen to the wall.

Installing the Upper and Lower Wall Mount Brackets

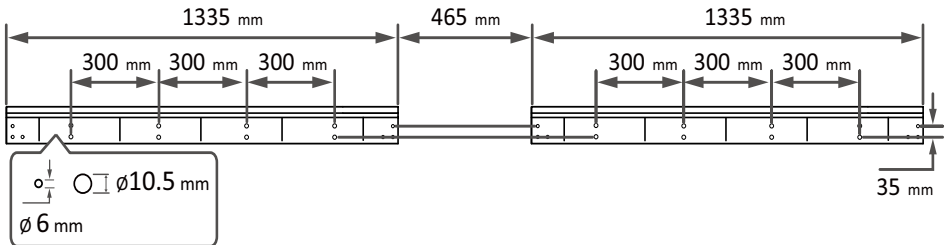

1. Ensure the wall area is an appropriate installation site.
NOTE: Refer to page 20 for more information.
2. Using the illustration as shown above as a guide, mark at least eight mounting holes and pre-drill them.
3. Install the first Upper Wall Mount Bracket with the provided screws (M8 x 80 mm Expansion for masonry; wood screws for load bearing wood).
4. Repeat **Step 2**, ensuring the second Upper Wall Mount Bracket is level with the first Upper Bracket.
NOTE: It is suggested to use a laser or torpedo level.
5. Install the Lower Wall Mount Brackets in the same manner as the Upper Wall Mount Brackets. The distance between the Upper and Lower Wall Mount Brackets is 1012.5 mm.

6. After installing both Upper and Lower Wall Mount Brackets, the installation wall should look like:

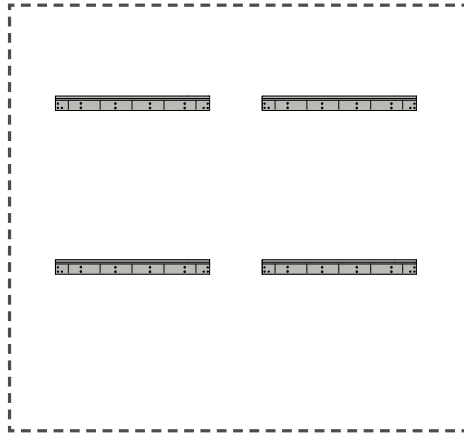

After the Wall Mount Brackets are installed, please go to page 29 for the Cabinets (Hidden Installation).

Spacing Instructions for Wall Installation (Hidden Installation)

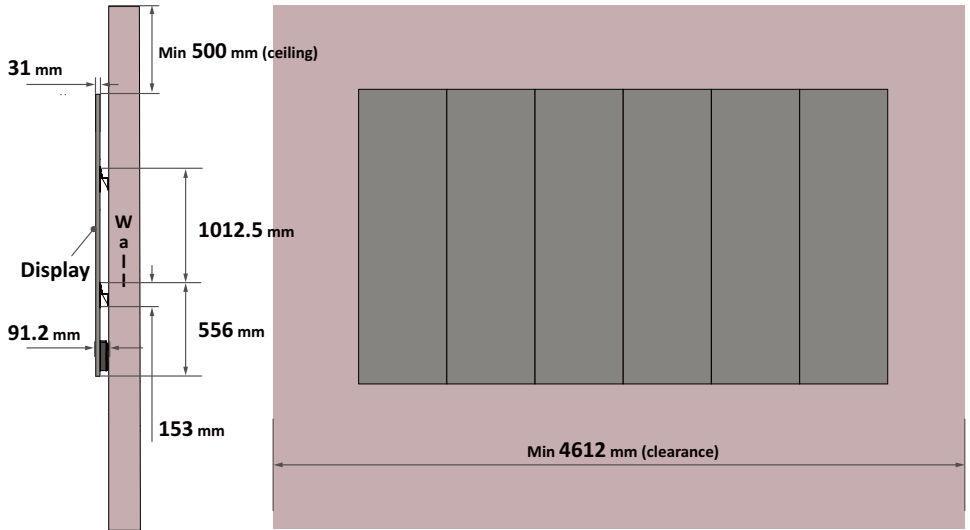

NOTE:

- You can also install the Upper Wall Mount Brackets, hang the screen, and then install the Lower Wall Mount Brackets for a more precise fit.
- Adjustment in floor clearance and ceiling height should be made according to the actual installation site.

Wall Mounting (Separate Installation)

When the System Control Box is installed apart from the Cabinets, this installation type uses the same Wall Mount Brackets as the Standard Installation. However, you will need to pre-drill additional holes for the System Control Box.

Drill Hole Spacing for System Control Box

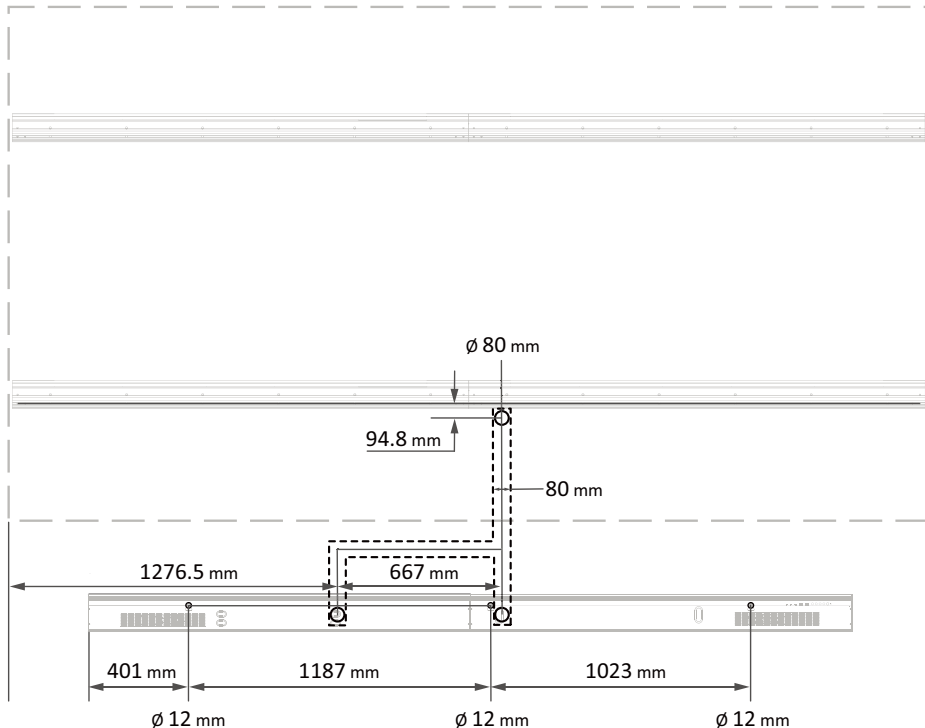

1. Please follow **Step 2~5** on page 10 for the Upper and Lower Wall Mount Brackets.

NOTE: To ensure the wall area is suitable for installation, refer to page 22 for more details.

2. Use the illustration as shown above as a guide to mark the following holes and pre-drill them.
 - At least three mounting holes for the System Control Box.
 - Three cable access holes, one at the top and two at the bottom. The distance between the Lower Wall Mount Bracket and the top cable access hole is 94.8 mm.

After the Wall Mount Brackets are installed, please go to page 23 for the Cabinets (Separate Installation).

Spacing Instructions for Wall Installation (Separate Installation)

ENGLISH

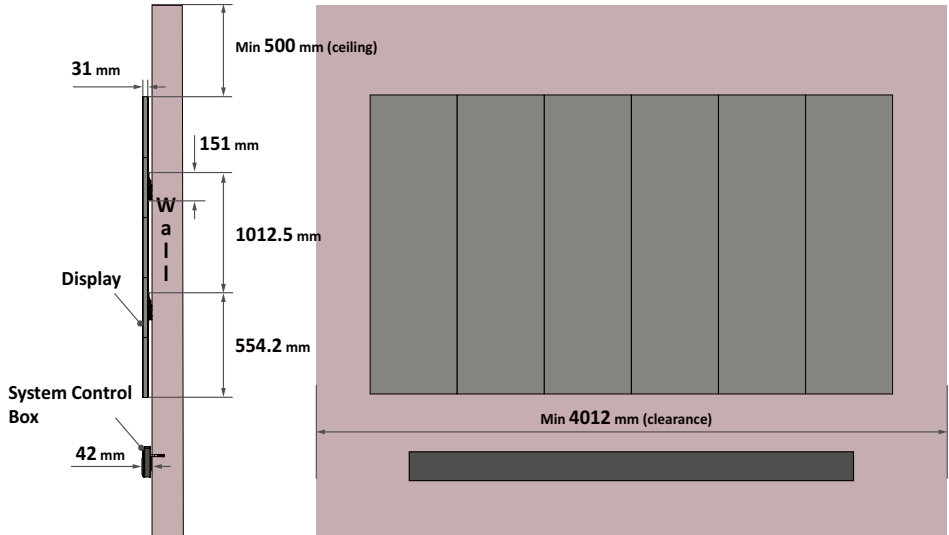

NOTE:

- You can also install the Upper Wall Mount Brackets, hang the screen, and then install the Lower Wall Mount Brackets for a more precise fit.
- Adjustment in floor clearance and ceiling height should be made according to the actual installation site.

Installing the Cabinets (Standard and Separate Installation)

The installation of the Cabinets are the same process for both the wall installation (Standard and Separate Installation) and trolley. However, if you use the trolley for your LED Display, please further secure the Cabinets with the supplied Cabinet Brackets.

Wall Installation

1. Carefully lift Cabinet "C" onto the center of the Upper Wall Mount Brackets.

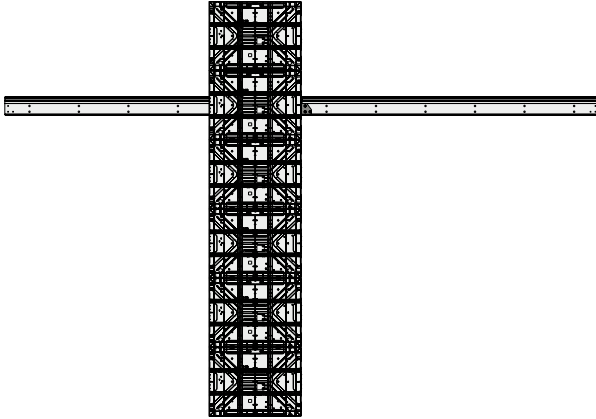

NOTE:

- One Cabinet weighs around 37.2 kg.
- You can identify Cabinets by the labels on the package.
- The arrow marks should be pointing up.

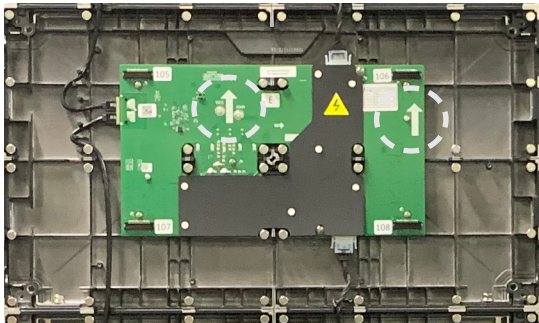

2. Ensure the Mounting Brackets sit securely on the Wall Mount Brackets as shown below.

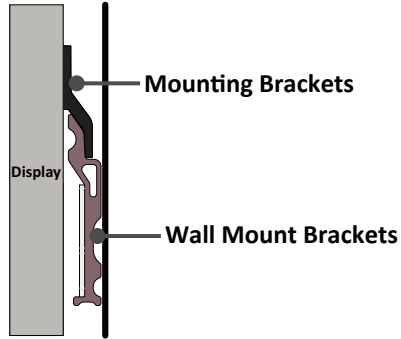

3. Lift Cabinet "D" and install it on the right side of Cabinets "C". Install the two Cabinets together with the provided screws (M8 x 20 mm).

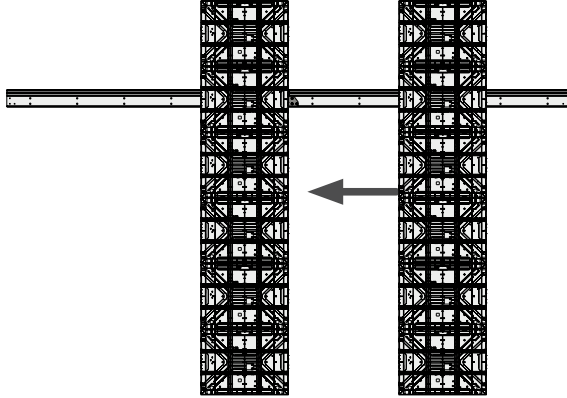

NOTE: There are 12 screws between each Cabinet.

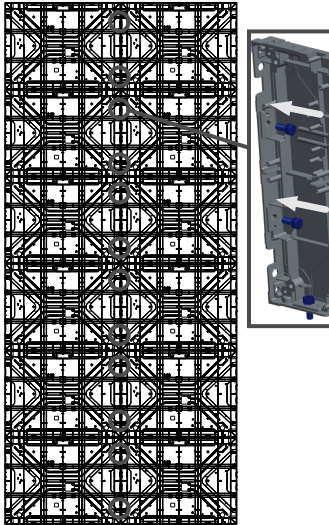

4. Check for unevenness of the Cabinets by rubbing the cross section between each Cabinet. If the cross section is not aligned, loosen the M8 screws slightly and tap the Cabinets until the cross section is flat.

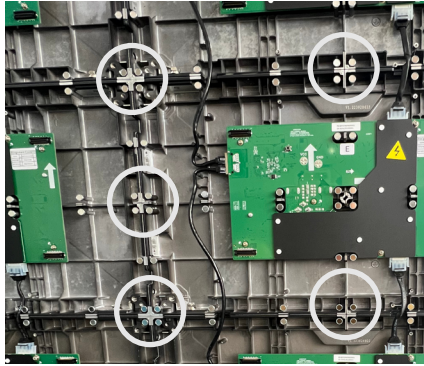

5. Place the remaining Cabinets onto the Wall Mount Brackets. Install from the center to the right and left sides of the Wall Mount Brackets.

NOTE: The installation sequence by Cabinet: C → D → B → E → A → F

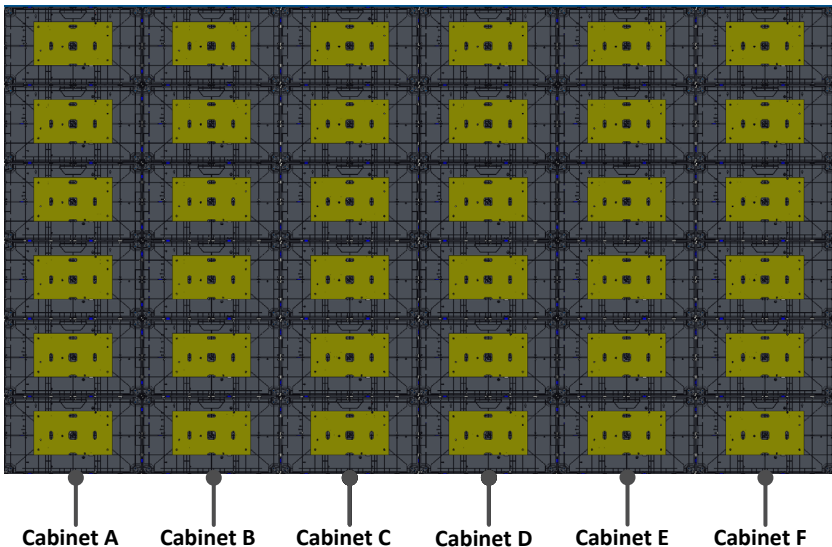

After all Cabinets are installed, please go to page 34 for the System Control Box (Standard Installation) or page 33 for the Cabinet Cable Extensions (Separate Installation).

NOTE: The Power Cable of each Cabinet must be extended first if the System Control Box is mounted either behind the Cabinets (Hidden Installation) or apart from the Cabinets (Separating Installation).

Trolley Installation

1. Please follow **Step 1~5** on page 23~26.
2. Adjust the left Cabinet Bracket until it is aligned with the hole provided in the Cabinet.

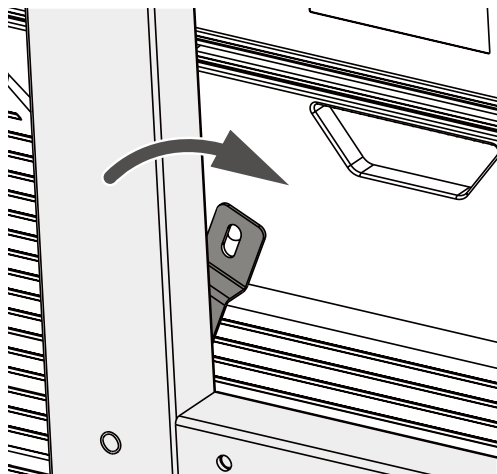

3. Secure the left Cabinet Bracket to the Cabinet with the provided screw (M8 x 20 mm).

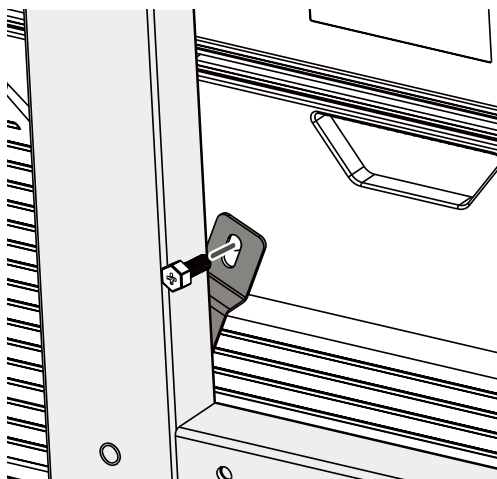

4. Install the right Cabinet Bracket in the same manner as the left Cabinet Bracket.

5. After all Cabinets are installed, the rear view of the trolley should look like:

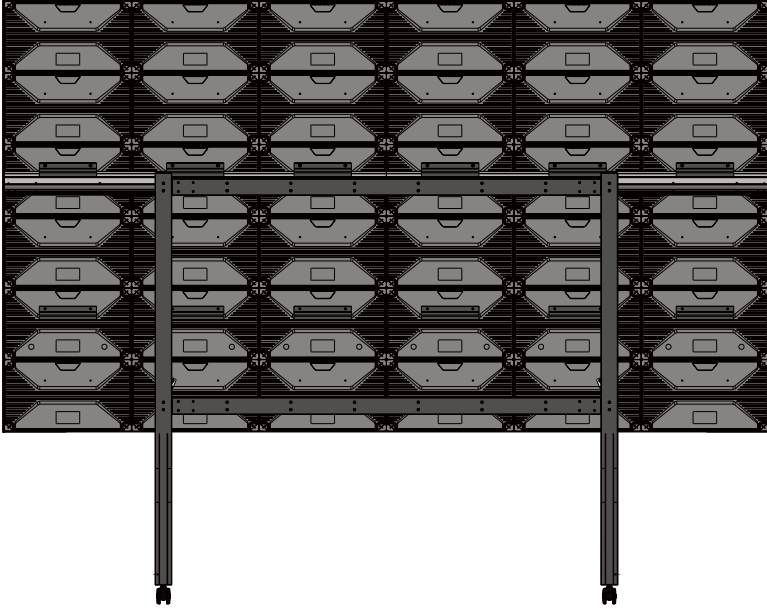

NOTE: When you use the trolley for your LED Display, the System Control Box can only be installed under the Cabinets (Standard Installation). Hidden and Separate Installation are not applicable to the trolley.

After all Cabinets are installed, please go to page 34 for the System Control Box.

Installing the Cabinets (Hidden Installation)

When the System Control Box is installed behind the Cabinets, the Upper System Control Box Mount Bracket must be mounted to the Cabinets first.

1. Place Cabinet "B" and Cabinet "D" face down on stable furniture that can safely support the two Cabinets.

NOTE:

- One Cabinet weighs around 37.2 kg.
- You can identify Cabinets by the labels on the package.
- The arrow marks should be pointing up.

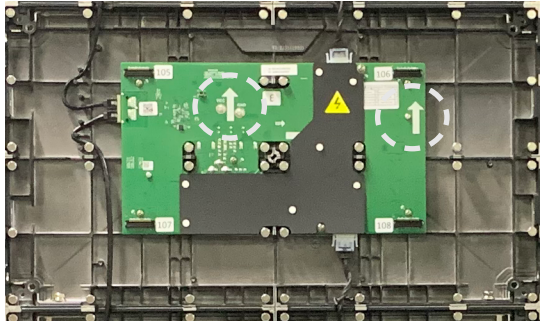

2. Install the Upper System Control Box Mount Brackets to the side of the two Cabinets "B" and "D" as shown below using the provided screws (M8 x 20 mm).

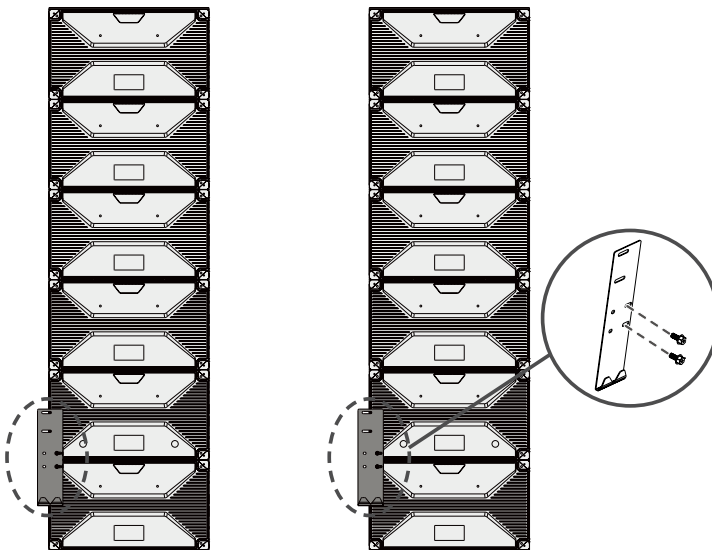

Rear View of Cabinet "B" (right) and Cabinet "D" (left)

3. Carefully lift Cabinet "C" onto the center of the Upper Wall Mount Brackets.

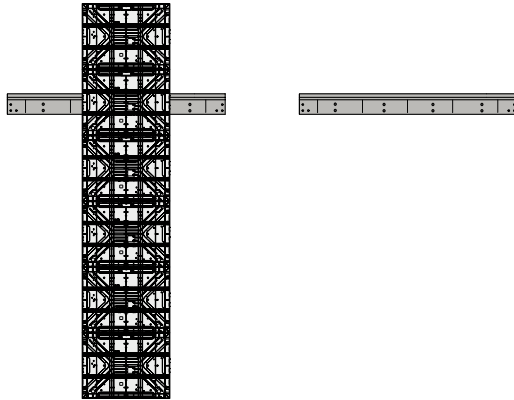

4. Ensure the Mounting Brackets sit securely on the Wall Mount Brackets as shown below.

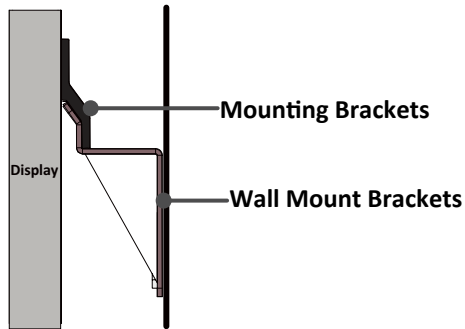

5. Install the Cabinet "D" to the right side of the Cabinet "C" with the provided screws (M8 x 20 mm).

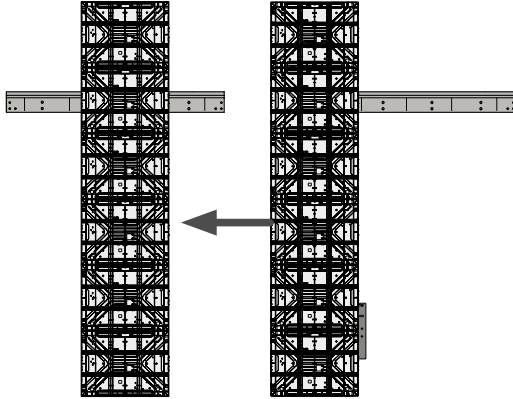

NOTE: There are 12 screws between each Cabinet.

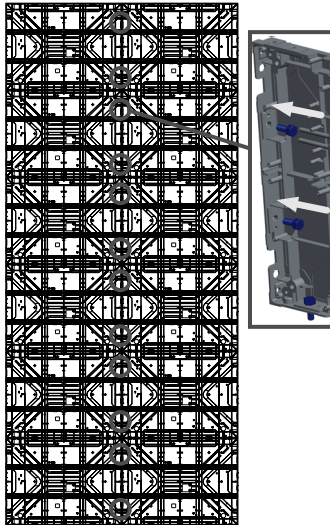

- Install the Cabinet "B" to the left side of the Cabinet "C" with the provided screws (M8 x 20 mm).

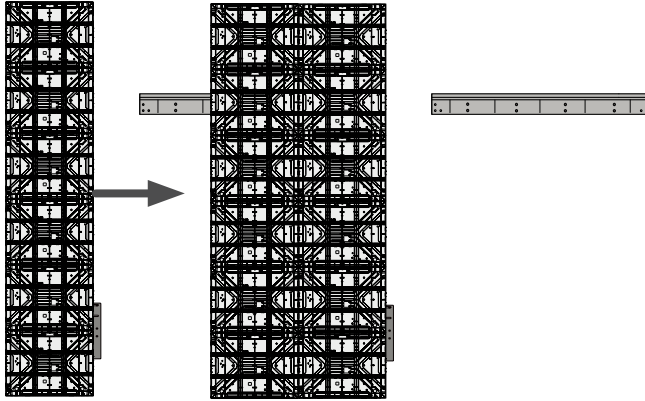

- Place the remaining Cabinets onto the Wall Mount Brackets. Install from the center to the right and left sides of the Wall Mount Brackets.

NOTE: The installation sequence by Cabinet: C → D → B → E → A → F

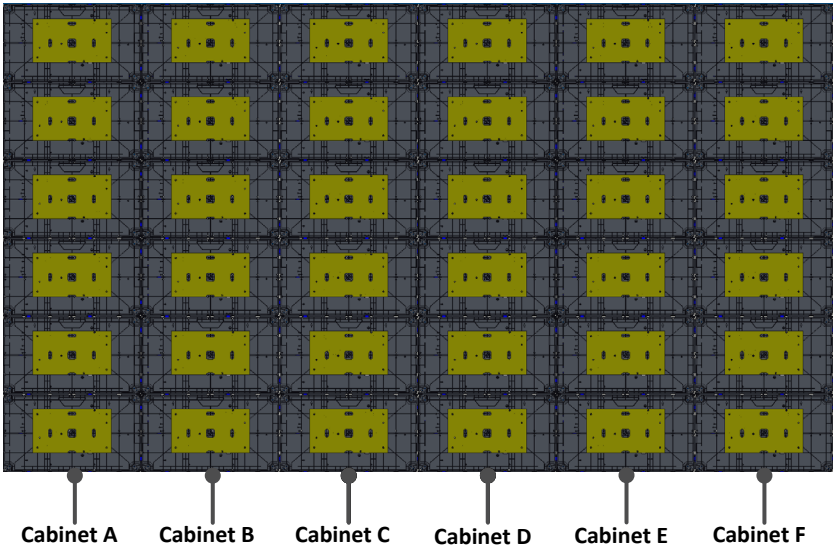

After all Cabinets are installed, please go to page 33 for the Cabinet Cable Extensions (Hidden Installation).

Extending the Power Cables

The Power Cables of the Cabinets must be extended first if the System Control Box is mounted **behind the Cabinets (Hidden Installation)** or **apart from the Cabinets (Separate Installation)**.

The Power Cables of the Cabinets are built in with the System Control Box.



Power Cable of Cabinet sections "A", "B", and "C"



Power Cable of Cabinet sections "D", "E", and "F"

1. Disconnect the Power Cables of the Cabinets from the System Control Box.
 ⚠ It is recommended to take photos of the completed wiring in the left and main system control boards before removing the Cables.
2. Replace the pre-installed Cabinet Cable Extension with the longer Cabinet Cable Extension. Ensure to match the corresponding letter on the longer Cabinet Cable Extension to the Power Cable.

NOTE: Cabinets are labeled on both the Power Cables and Cabinet Cable Extensions.

3. Fully cover the joint with the supplied electrical tape, ensuring to wrap it with at least 25 mm for better protection.



4. Repeat **Step 2~3** for the other Cabinet Cable Extensions.

NOTE: There are six Cabinet Cable Extensions to connect.

After all Power Cables are extended, please go to page 41 (Hidden Installation) or page 49 (Separating Installation) for the System Control Box.

Connecting the System Control Box (Standard Installation)

The left and right sides of the System Control Box are pre-installed with its Covers in the factory. The main system control board is on the right.

- ❗ The safety wires are used to prevent the Right Cover from falling when accessing the System Control Box. Please ensure that the safety wires are never removed.
- ❗ Use caution as the System Control Box panel is separated into two pieces with wires attached.

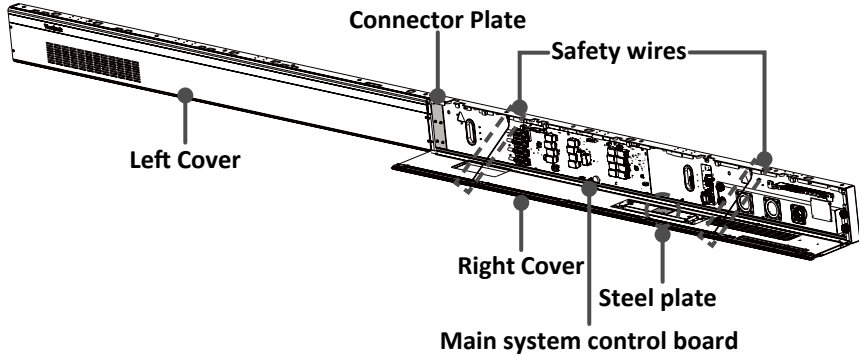

1. Carefully place the System Control Box on stable furniture that can safely support the System Control Box.
 2. To open the Right Cover, slowly bring the supplied System Control Box Maintenance Tool near the surface of the Right Cover where the steel plate is located. Then, the Right Cover should detach from the System Control Box magnetically.
- ❗ DO NOT try to remove or disconnect the safety wires. Please ensure that the safety wires are never removed.

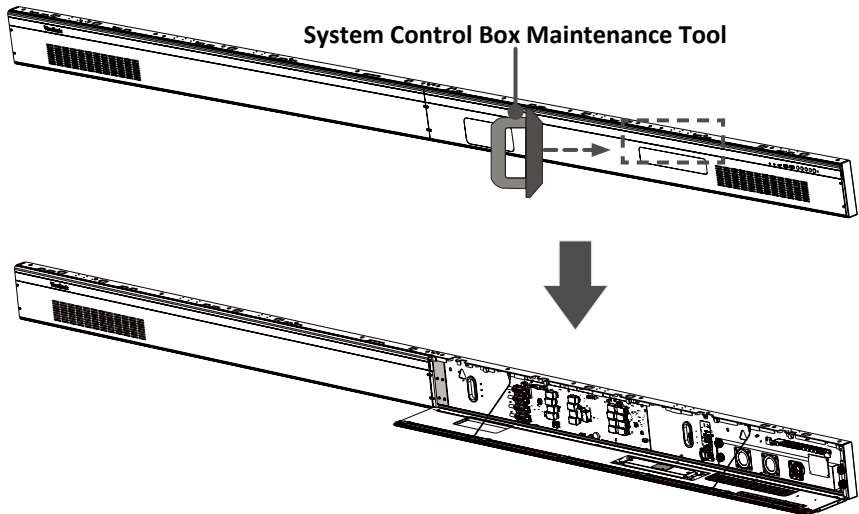

3. Remove the Left Cover by gripping the top edge of the Cover and pulling it toward you. The Left Cover should simply lift away.

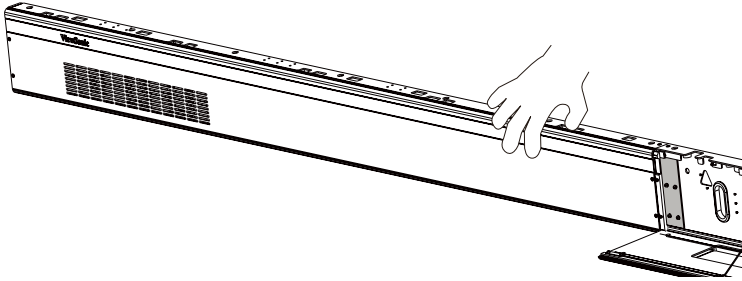

4. Secure the System Control Box panel with the Connector Plate using the provided screws (M3 x 6 mm).

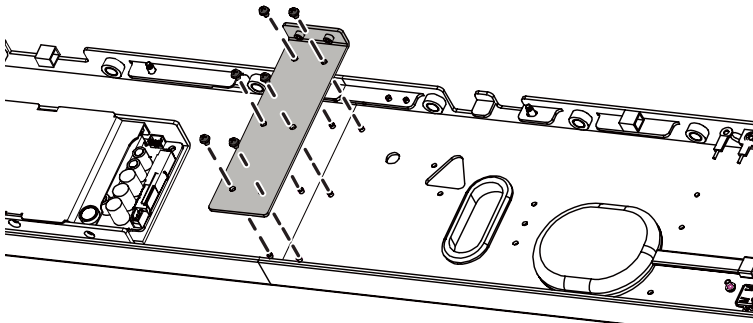

5. Further secure the Connector Plate with the two provided screws (M3 x 6 mm).

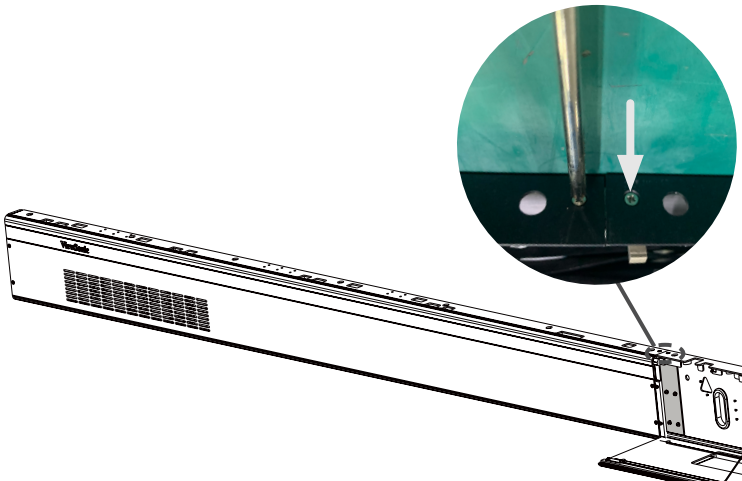

9. Connect the Power and Network Cables from the System Control Box to each Cabinet. Ensure to match the corresponding letters on the Cables to the Cabinets (A to A, B to B, C to C, and so on).

NOTE:

- Each Cabinet has one Power and one Network Cable to connect.
- Only the Cables at the lowest row of the Cabinets need to be connected.

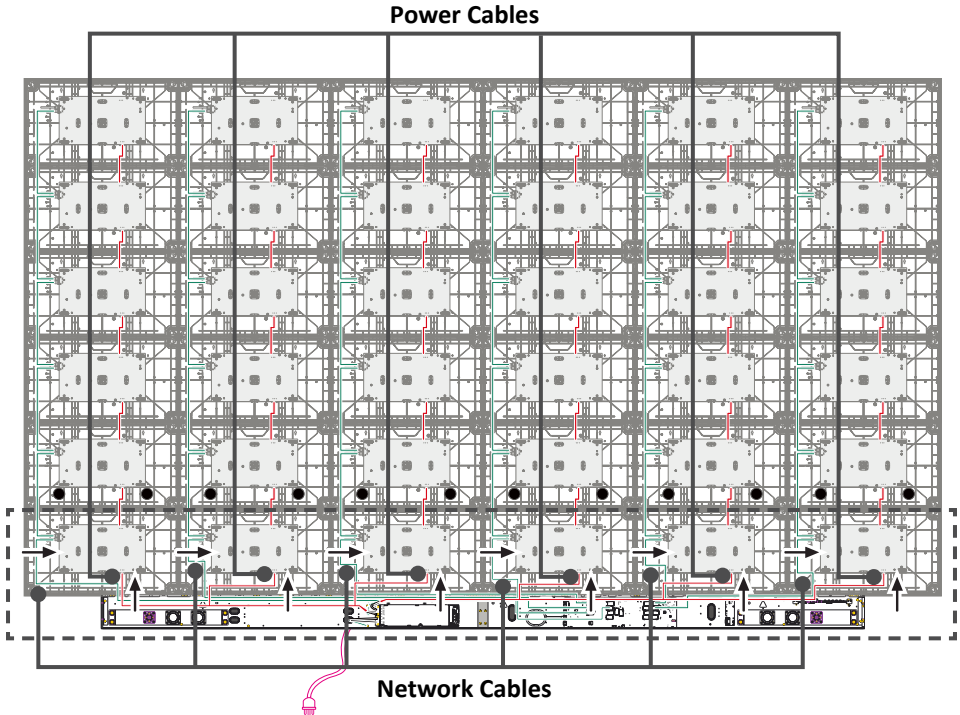

10. Connect the left system control board to the main system control board.

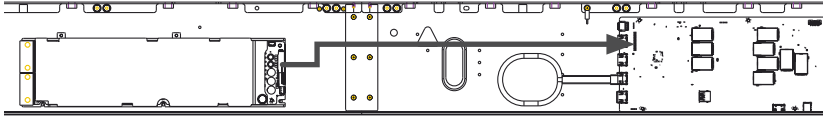

11. Connect the LED Display's left speaker to the Audio Out port of the system control board.

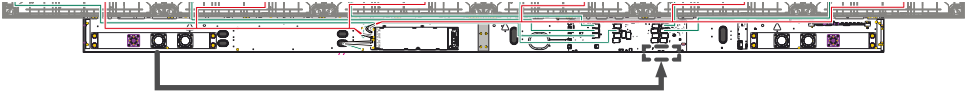

NOTE: Ensure the right speaker is properly connected to the other Audio Out port.

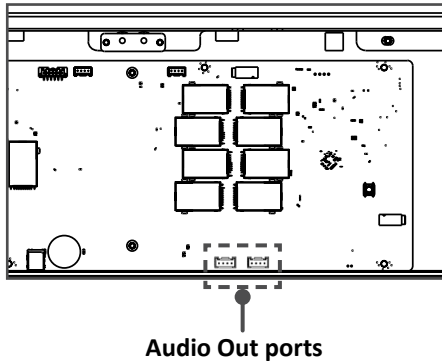

12. Ensure the AC unit of the System Control Box is properly connected.

❗ DO NOT connect the System Control Box Power Cables at this time.

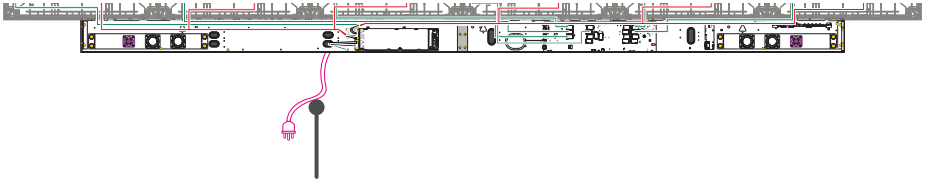

System Control Box Power Cables

- The neutral wires (usually white/blue) are connected to the "N1", "N2", and "N" terminals.
- The hot wires (usually black/brown) are connected to the "L1", "L2", and "L" terminals.
- The input and output terminals are properly grounded (2 x AC OUT and 1 x AC IN, usually in green).

❗ The meaning of wiring color may vary by country.

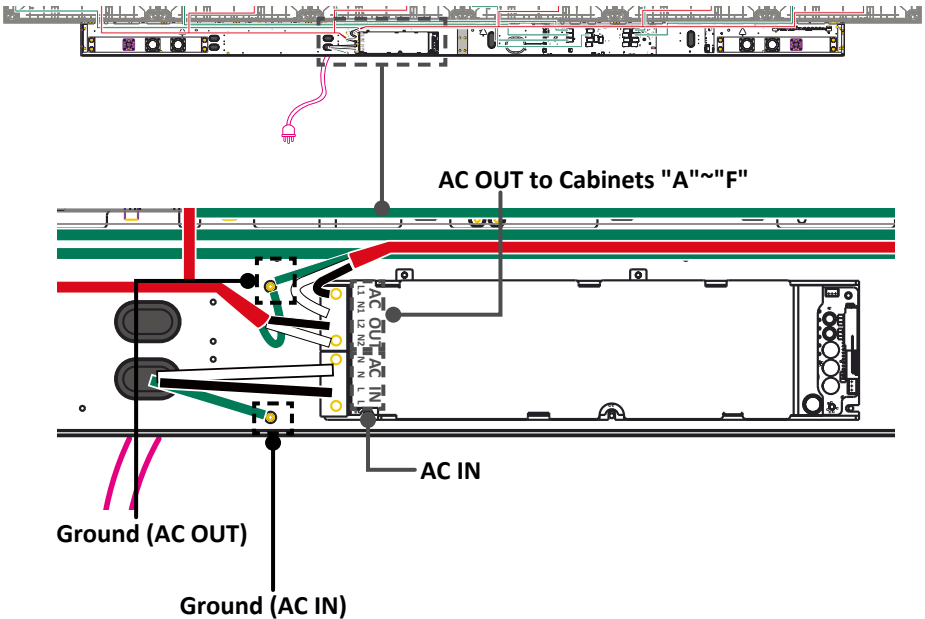

13. After connecting all Cables and wires, hold the top edge of the Right Cover toward the System Control Box to replace it. Once the Right Cover is replaced, it will be held in place magnetically.

NOTE: Ensure the Power Button cable is connected before securing the Right Cover.

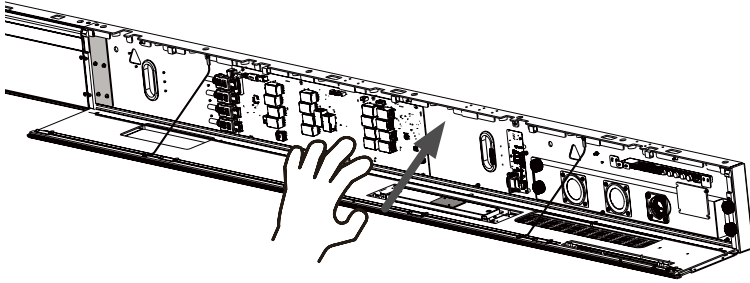

14. Replace the Left Cover by aligning it properly with the System Control Box; then the Left Cover should attach magnetically.

After the System Control Box is connected, please go to page 52 for the LED Modules.

Connecting the System Control Box (Hidden Installation)

The left and right sides of the System Control Box are pre-installed with its Covers in the factory. The main system control board is on the right.

- ❗ The safety wires are used to prevent the Right Cover from falling when accessing the System Control Box. Please ensure that the safety wires are never removed.
 - ❗ Use caution as the System Control Box panel is separated into two pieces with wires attached.
 - ❗ Before installing the System Control Box, the Power Cables of the Cabinets must be extended first. You also need the longer Network Cables supplied in the case for this installation type. Please refer to page 33 for more details.
1. Please follow **Step 1~5** on page 34~35 for the System Control Box and the Connector Plate.
 - ❗ DO NOT try to remove or disconnect the safety wires. Please ensure that the safety wires are never removed.
 2. Install the short side of the Lower System Control Box Mount Bracket onto the top of the System Control Box with the provided screws (M3 x 6 mm).

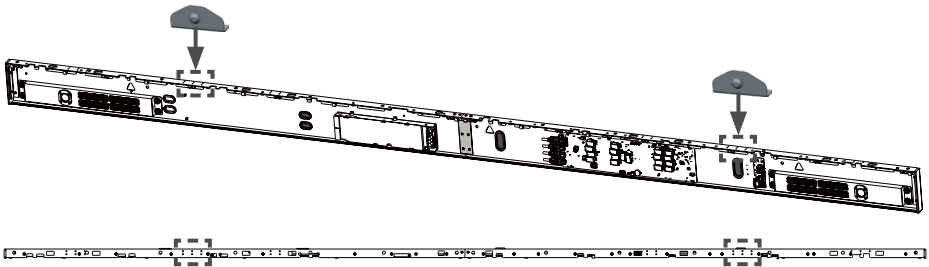

Installing the Lower System Control Box Mount Brackets onto the System Control Box (Front and Top Views)

3. Install the provided screw (M8 x 16 mm) on the Lower System Control Box Mount Bracket. Thread the provided M8 nut onto the screw and fully tighten the nut.

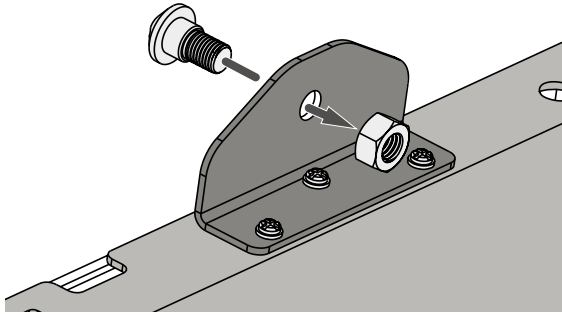

Installing the provided screw and nut to the Brackets (Rear View)

4. Repeat **Step 2~3** for the other Lower System Control Box Bracket.
5. The rubber hole plugs installed on both the System Control Box and Cabinets are used to protect the Cables from rubbing against any pointed edges. Use a knife to cut the hole to size along the cross.

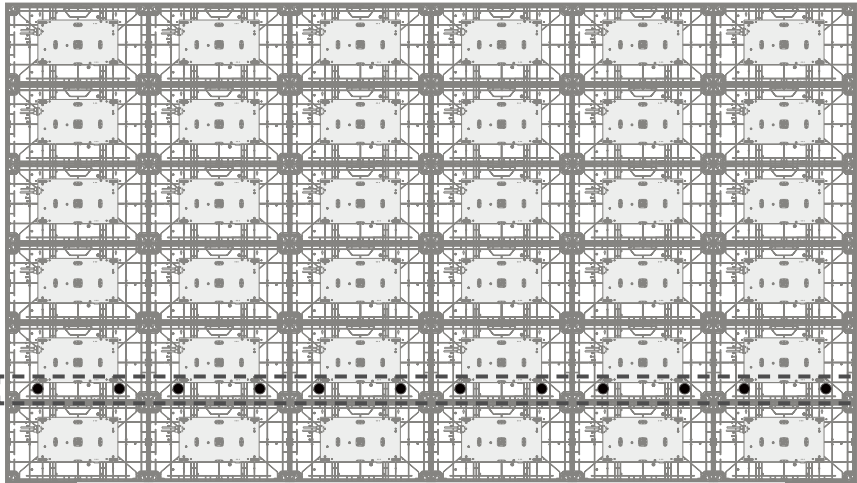
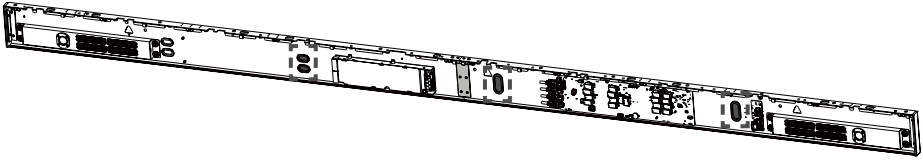

6. Remove the pre-installed Power and Network Cables of the Cabinets from the System Control Box.

NOTE:

- There are six Power and six Network Cables to remove.
 - It is recommended to take photos of the completed wiring in the left and main system control boards before removing the Cables.
7. After removing the pre-installed Network Cables of the Cabinets, connect one end of the longer Network Cable to the network port that was disconnected from the System Control Box in **Step 6**.

NOTE:

- There are six Network Cables to connect.
 - Ensure to match the corresponding letters on the Cables to the network ports of the System Control Box (A to A, B to B, C to C, and so on).
8. Carefully thread the six Network Cables through the hole provided in the System Control Box to the rear. Avoid sharp bends in the Cables.

NOTE: The rubber hole plugs must always be placed in the holes.

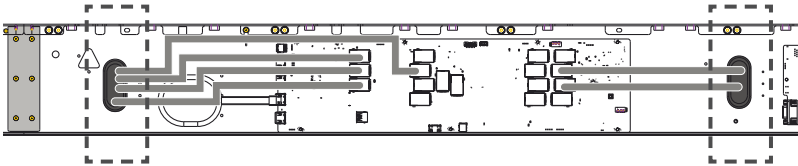

9. After threading the Network Cables, please follow the diagram below to connect the extended Power Cables to the AC unit of the System Control Box.

! DO NOT connect the System Control Box Power Cables at this time.

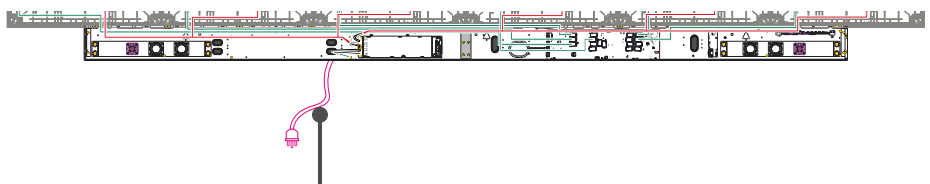

System Control Box Power Cables

- Connect the neutral wires (usually white/blue) to the "N1" and "N2" terminals.
- Connect the hot wires (usually black/brown) to the "L1" and "L2" terminals.
- Connect the ground wires (usually in green) to the ground terminals.
- !** The meaning of wiring color may vary by country.
- !** Use the provided wrench to tighten the neutral, hot, and ground conductors in the terminals properly.

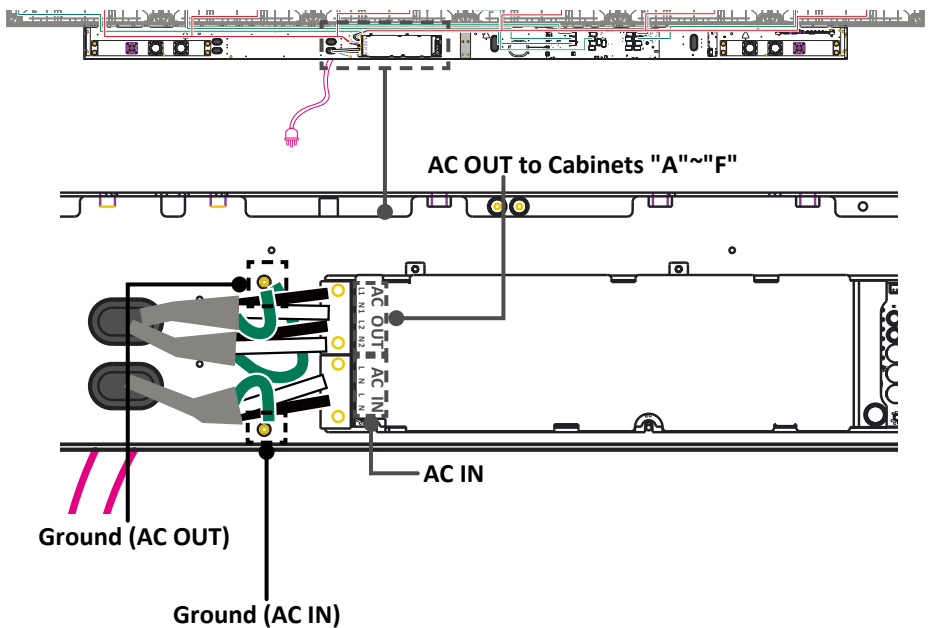

10. Thread the Power Cables of the Cabinets through the hole provided in the System Control Box to the rear. Avoid sharp bends in the Cables.

NOTE:

- There are two Power Cables to thread.
- The rubber hole plugs must always be placed in the holes.
- Before threading the Cables through, ensure that the output and input terminals (2 x AC OUT and 1 x AC IN) are properly grounded, and that the wire colors/labels are matched with the marked terminals. Each wire is screwed firmly to its corresponding terminal as well.

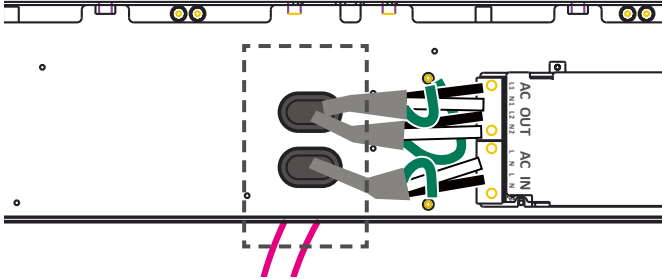

11. Please follow **Step 10~11** on page 38 for the system control board.

NOTE: After the IR Extension Cable is connected, route it through the adjacent cable hole as highlighted below to the rear.

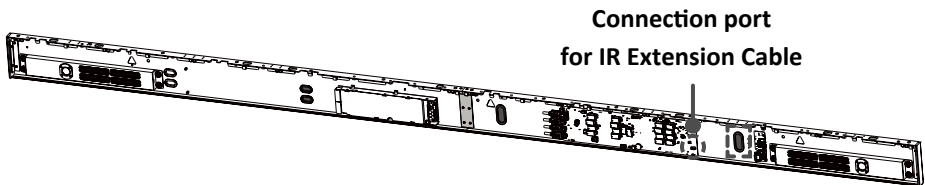

12. After all Cables and wires are properly connected, please follow Step 13~14 on page 40 for the System Control Box Covers.

NOTE: Please ensure there are no sharp bends in the Cables and wires.

13. Align the Lower System Control Box Mount Brackets with the Upper Mount Brackets to attach.

14. Thread the Power and Network Cables through the holes provided in the Cabinets to the front. Ensure to match the corresponding letters on the Cables to the Cabinets (A to A, B to B, C to C, and so on).

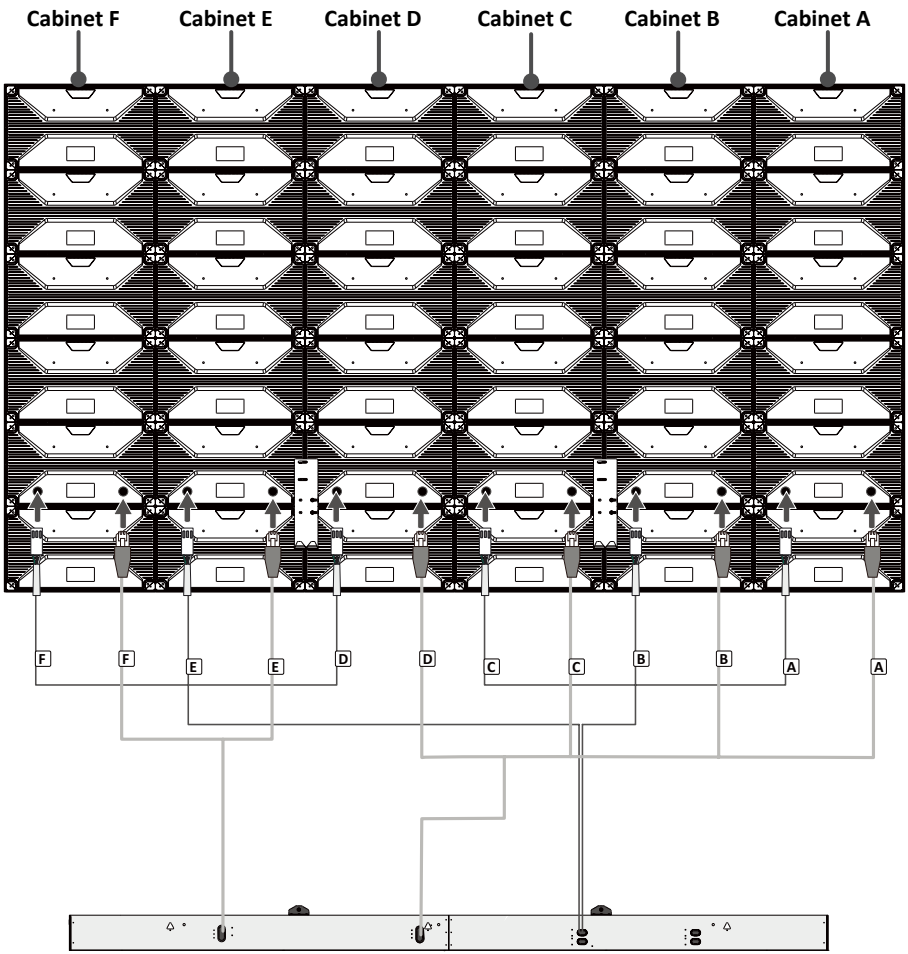

Threading the Power and Network Cables from behind (Rear View)

15. Carefully place the Lower System Control Box Mount Brackets onto the Upper System Control Box Mount Brackets.

NOTE: To avoid sharp bends in the Cables, please pull them into the Cabinets and manage the Cables there.



Placing the Lower System Control Box Mount Bracket onto the Upper (Rear View)

16. Ensure the Lower System Control Box Mount Brackets sit securely on the Upper.

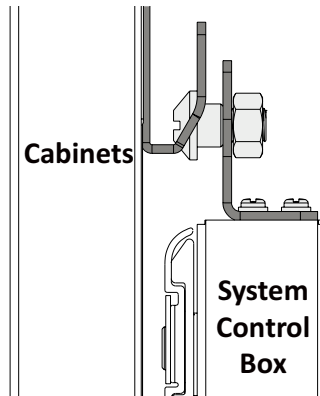

17. Connect the connector of the extended Power Cable to the power port of the Cabinet. Then, connect the other end of the Network Cable to the network port of the Cabinet. Ensure to match the corresponding letters on the Cables to the Cabinets (A to A, B to B, C to C, and so on).

NOTE: Each Cabinet has one Power and one Network Cable to connect.

Network Cables

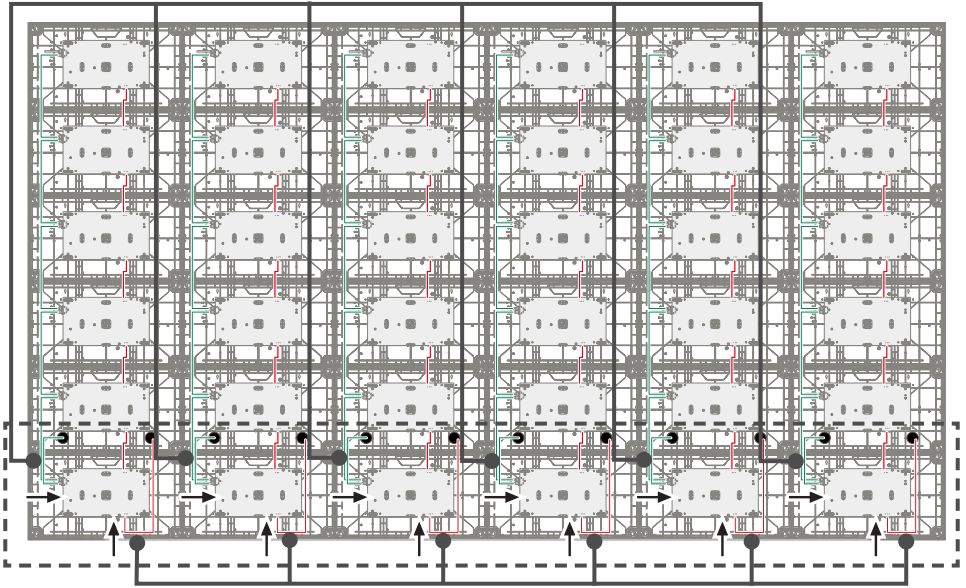

Power Cables

18. Route the Power and Network Cables around the rods provided in the Cabinets and secure the Cables to the rods with the Cable Zip Tie and screw (PM3 x 10 mm). Leave a little slack for later adjustments if needed.

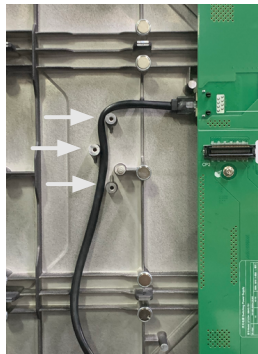

After the System Control Box is connected, please go to page 52 for the LED Modules.

Connecting the System Control Box (Separate Installation)

The left and right sides of the System Control Box are pre-installed with its Covers in the factory. The main system control board is on the right.

- ❗ The safety wires are used to prevent the Right Cover from falling when accessing the System Control Box. Please ensure that the safety wires are never removed.
 - ❗ Use caution as the System Control Box panel is separated into two pieces with wires attached.
 - ❗ Before installing the System Control Box, the Power Cables of the Cabinets must be extended first. You also need the longer Network Cables supplied in the case for this installation type. Please refer to page 33 for more details.
1. Please follow **Step 5** on page 42 for the rubber hole plugs.
 2. Connect the connector of the extended Power Cable to the power port of the Cabinet. Then, connect one end of the longer Network Cable to the network port of the Cabinet. Ensure to match the corresponding letters on the Cables to the Cabinets (A to A, B to B, C to C, and so on).

NOTE: Each Cabinet has one Power and one Network Cable to connect.

Network Cables

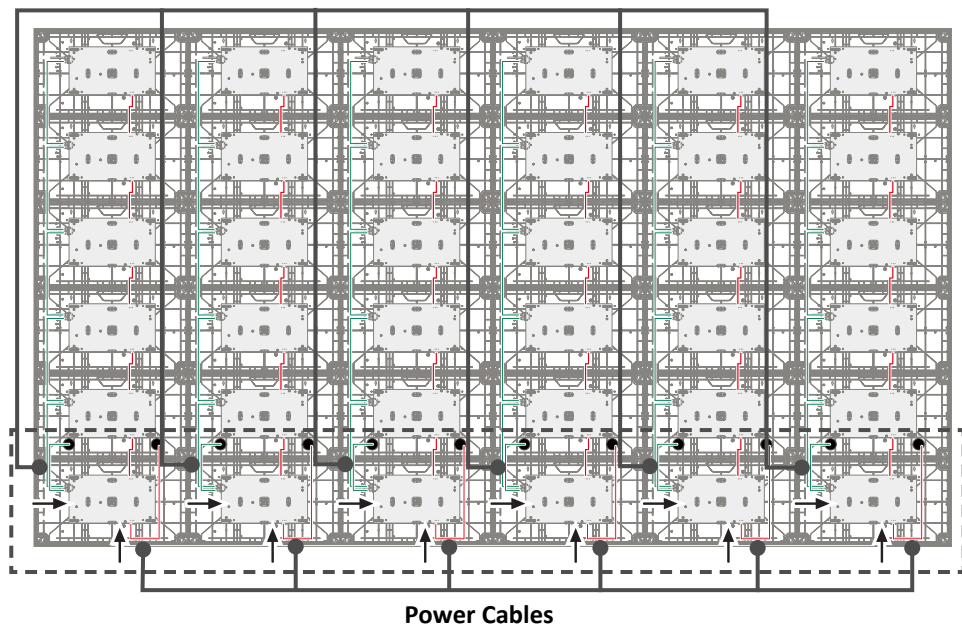

3. After connecting the Power and Network Cables, carefully thread them through the holes provided in the Cabinets and run the Cables behind the Cabinets from the top cable access hole through the bottom cable access holes.
 - ❗ Avoid sharp bends in the Cables.
4. Please follow **Step 1~5** on page 34~35 for the System Control Box and the Connector Plate.
 - ❗ DO NOT try to remove or disconnect the safety wires. Please ensure that the safety wires are never removed.
5. Place the System Control Box accordingly over the drilled mounting holes to attach.
6. Carefully thread the Power and Network Cables through the holes provided in the System Control Box from behind. Ensure to use the correct cable holes for the Power and Network Cables.

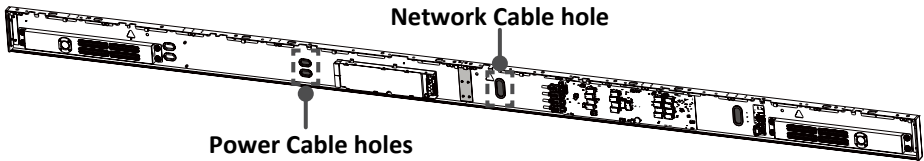

7. After threading the Power and Network Cables, install the System Control Box onto the wall with the provided screws (M8 x 80 mm Expansion for masonry; wood screws for load bearing wood).

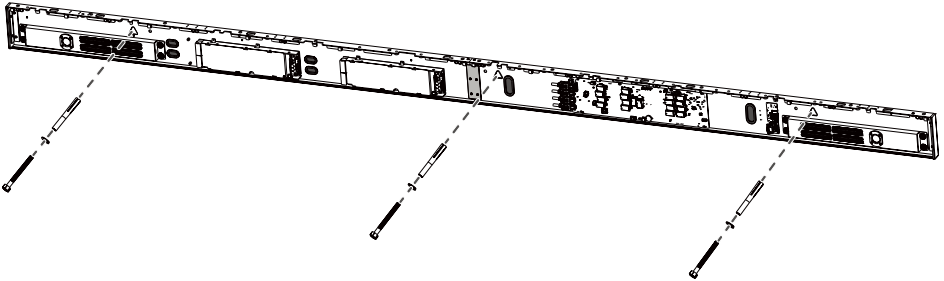

8. Remove the pre-installed Power and Network Cables of the Cabinets from the System Control Box.

NOTE:

- There are six Power and six Network Cables to remove.
 - It is recommended to take photos of the completed wiring in the left and main system control boards before removing the Cables.
9. After removing the pre-installed Power and Network Cables of the Cabinets, connect the other end of the longer Network Cables to the network port that was disconnected from the System Control Box in **Step 8**.

NOTE: There are six Network Cables to connect.

10. Please follow **Step 9** on page 44 for the Power Cables.
11. Route the Power and Network Cables around the rods provided in the Cabinets and secure the Cables to the rods with the Cable Zip Tie and screw (PM3 x 10 mm). Leave a little slack for later adjustments if needed.

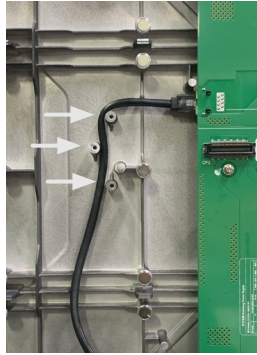

12. Please follow **Step 10~11** on page 38 for the system control board.

NOTE: After the IR Extension Cable is connected, route it through the adjacent cable hole as highlighted below to the rear.

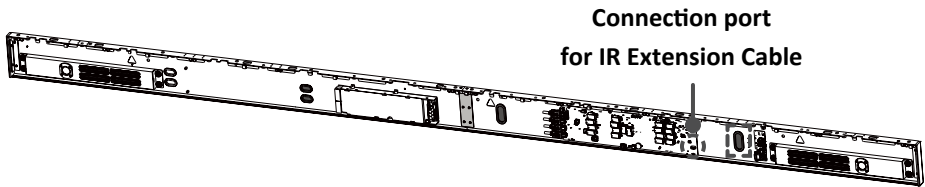

13. After all Cables and wires are properly connected, please follow **Step 13~14** on page 40 for the System Control Box Covers.

⚠ Please ensure there are no sharp bends in the Cables and wires.

After the System Control Box is connected, please go to page 52 for the LED Modules.

Installing the LED Modules

- ❗ Please wear Anti-Static Gloves before handling the LED Modules.
- ❗ To avoid direct contact with the LED Modules, please remove watches, rings, bracelets, or other metal objects.
- ❗ Use caution when installing the LED Modules.

1. Starting from the LED Module labeled "1" in the top left corner, align each LED Module with the Cabinet, then carefully press the Module into place.

NOTE: The arrow mark on the back of the LED Modules should be pointing up.



2. Attach the remaining LED Modules onto the Cabinets. Install from top left and move to bottom right, ensuring to match the corresponding numbers on the Module to the Cabinet.

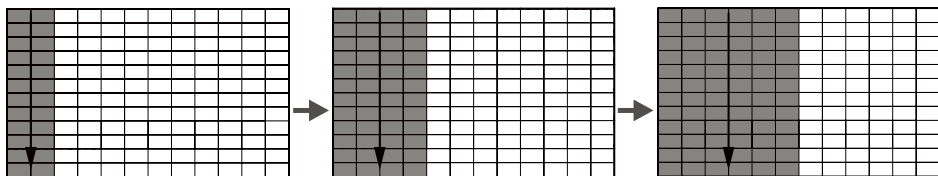

NOTE: Before installing the LED Module, ensure that each Module is flush and that there is little to no gap between each. It may be necessary to gently tap the module to make it flush.

After all LED Modules are installed, please go to page 53 (Standard Installation) or page 55 (Hidden and Separate Installation) for the Screen Bezels.

Installing the Screen Bezels (Standard Installation)

- ❗ The Screen Bezels' plastic tabs are pre-installed onto the Bezels. Ensure all plastic tabs are properly mounted before installing the Screen Bezels onto the screen.
- ❗ The label indicates the top of each Screen Bezel. To ensure the Bezels are installed in the correct position, please use the labels on the inside of the Bezels as a guide.



1. Place the Screen Bezels to the correct side of the screen to attach. Start from the left and move to the right.

NOTE:

- Ensure the label side of the Screen Bezel is facing the screen.
- Before installing the Screen Bezels, check the label of each Bezel as the label helps you know which side ("L" = left side & "R" = right side) to attach the Bezel.
- The illustration below shows the location where each Screen Bezel should be installed.

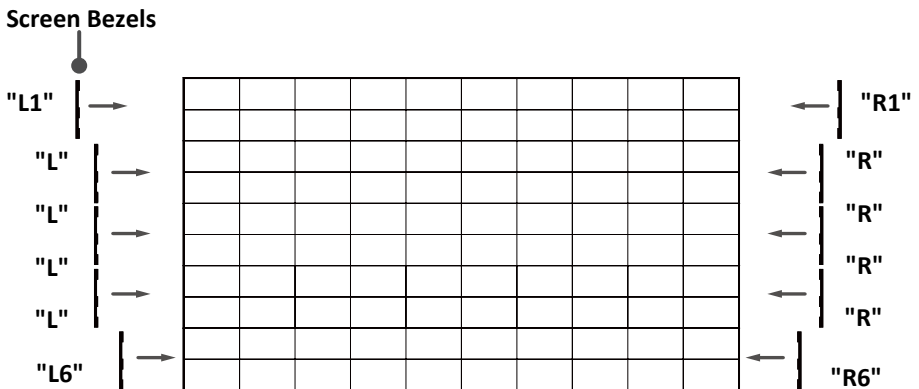

2. Align the plastic tabs of the Screen Bezel with the holes provided in the screen.



3. Press down on the Screen Bezel until you hear it click into place.
 4. Place the remaining Screen Bezels onto the left and right sides of the screen.
- NOTE:** There are six Screen Bezels on either left or right side of the screen to install.

After all Screen Bezels are installed, please go to page 57 to finish the installation.

Installing the Screen Bezels (Hidden and Separate Installation)

- ❗ The Screen Bezels' plastic tabs are pre-installed onto the Bezels. Ensure all plastic tabs are properly mounted before installing the Screen Bezels onto the screen.
- ❗ The label indicates the top of each Screen Bezel. To ensure the Bezels are installed in the correct position, please use the labels on the inside of the Bezels as a guide.



1. Please follow **Step 2~4** on page 53 for the left and right sides of the Screen Bezels. Start from the left and move to the right.

NOTE:

- Ensure the label side of the Screen Bezel is facing the screen.
- Before installing the Screen Bezels, check the label of each Bezel as the label helps you know which side ("L" = left side & "R" = right side) to attach the Bezel.
- The illustration below shows the location where each Screen Bezel should be installed.

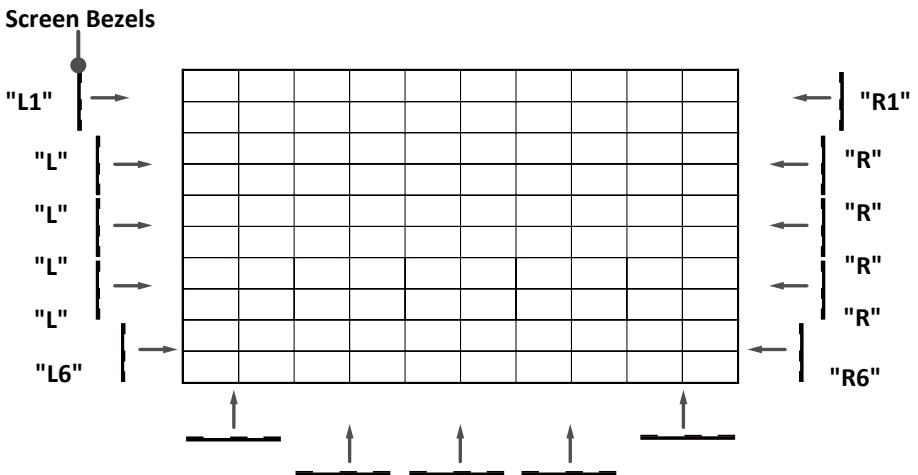

- At the bottom of the screen, loosen the screws securing the pre-installed Screen Bezel and remove it. This provides enough room to the bottom Screen Bezels.

NOTE: There are two pre-installed Screen Bezels to remove.

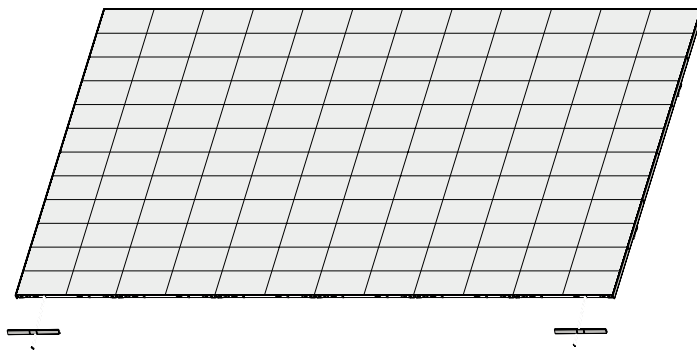

- Install the bottom Screen Bezel to the screen with the four provided screws (M3 x10 mm).

NOTE: There are six bottom Screen Bezels to install.

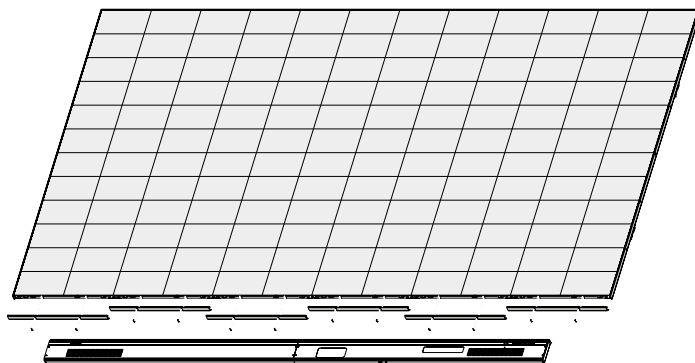

After all Screen Bezels are installed, please go to page 57 to finish the installation.

Turning On the LED Display

1. Make sure the System Control Box Power Cable is connected and plugged into a power outlet.

NOTE: When the System Control Box Power Cable is connected to a power outlet, the Power Indicator Light will be a steady red. This means the LED Display is in standby mode. Please refer to the User Guide for more details.

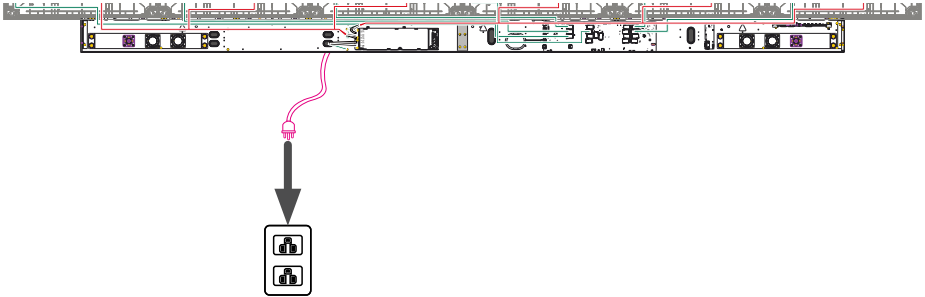

2. Your LED Display is now ready to power on.



ViewSonic®